

The Complete Book on Rubber Processing and Compounding Technology

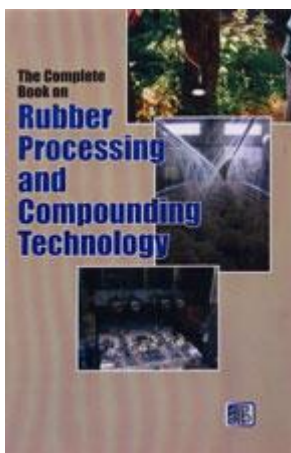

Author: NIIR Board of Consultants and Engineers

Format: Paperback

ISBN: 8178330059

Code: NI174

Pages: 712

Price: Rs. 1,275.00 US\$ 125.00

Published: 2006

Publisher: Asia Pacific Business Press Inc.

Usually ships within 5 days



Rubber products industry is an important resource based industry sector in India. Over the last decade the rubber industry has witnessed a steady and strong growth. Rubber can be deformed to a high degree of strain in a reversible manner and this special property finds use in fields as diverse as transportation, material handling, health care, and sport and leisure activities. The book covers manufacturing processes of rubber products, compounding of rubber, quality assurance, applications etc. Thus book is very useful for new entrepreneurs, existing units, technical institutions, technocrats etc.

[^ Top](#)

Related Books

- [Modern Technology Of Rubber & Allied Industries](#) [NI21] by NIIR Board, **Rs. 0.00, US\$ 0.00**
- [All India Rubber & Rubber Products Manufacturers Directory](#) [NID84], **Rs. 1,655.00, US\$ 150.00**

Contents

[Hide](#) ▼

1 RUBBERS: MATERIALS AND PROCESSING TECHNOLOGY

Natural Rubber Plantation

Tapping of Rubber Latex

Preservation and Coagulation of Latex

Chemical Nature of Natural Rubber Hydrocarbon

Hydrogenated Rubber
Cyclized Rubber
Chlorinated Rubber
Rubbers from Stereo-regular Polymerization of Isoprene and Butadiene
Styrene-Butadiene Rubber (SBR)
Polychloroprene Rubber (CR)
Nitrile Rubber (NBR)
Butyl Rubber (IIR)
Ethylene-Propylene-Diene Terpolymer (EPDM)
Polysulphide Rubber (PSR)
Polyacrylic Rubber or Acrylate Rubber (ACR)
Fluorocarbon Rubber (FKM)
Introduction
Mastication and Mixing
Open Mill
Internal Mixers
Reclaimed Rubber
Fillers
Antidegradants
Accelerators
Retarders
Activators
Tyres
Belting and Hoses
Cellular Rubber Products
Miscellaneous Applications of Rubber
Passenger Tyre
Tube Compound for Car tyres
Conveyor Belts
Insulation Compound for Cables
Shoe Soles
2 MIXING TECHNOLOGY OF RUBBER
Two-roll Mills
Internal Batch Mixers
Continuous Mixers
Advantages of continuous mixing
Disadvantages of continuous mixing
Development of the Banbury Mixer
Operating Variables
Ram Pressure
Rotor Speed
Batch Size
Coolant Temperature
Unit Operations in Mixing
Single-Pass Versus Multiple-Pass Mixing
Types of Mix Cycle

Late Oil Addition
Upside-down Mixing
Sandwich Mixes
Analysis of Changes to the Mix Procedure
Acceleration of First-pass Compound
Mill Mixing of Speciality Compounds
Acceleration in Line with Internal Mixing
Testing of Raw Materials
Elastomers as Raw Materials
Fillers
Plasticisers and Process Oils
Small Ingredients
Control of Composition
Tracking the Mix Cycle
Compound Testing
Basic SPC Charting
Rheometer Data and its Meaning
Mixing Control Software
Peptisers in Natural Rubber
Effects of Temperature
Effects of Time
Effects of Use Level
Effects of Other Additives
Peptisers in SBR
Peptisers in Sulphur-containing Polymers
Additives to Increase Viscosity
Preventing Unwanted Chemical Reactions
Filler Treatments
Bin Storage Problems
Inspection of Banbury Mixers
Inspection at the Mezzanine Level
Side Cooling
Rotor Cooling
Rotors and Bearings
Rotor Bearing Lubrication
Dust Stops
Drop Door and Latch
Hydraulic System
Grease System
Dust Stop Lubrication
Drive Gears
Couplings
Inspection of the Banbury Platform
Ram and Cylinder
Heating Weight
Piston Rod

Weight Pin Assembly
Hopper Door
Air Line Filter
Hopper Operation
Mixer Maintenance and Lubrication
Each time the mixer is started
Once per shift
Once per day
Once per week
Once per month
Every six months
Anticipating Required Service
Dust Stop Maintenance
SSA Dust Stops
Assembly
Lapping
Running
Banbury Mixer — Hydraulic Dust Stops
Assembly
Run-in
Lapping
Production
Flushing
EPDM Expansion Joint Cover
Expansion Joint Intermediate Layer
Traffic Counter Treadle Cover
SBR/IR Belt Cover
EPDM Low Voltage Electrical Connector
Peroxide-cured Black-filled EPDM Compounds
EPDM Concrete Pipe Gasket
Injection-moulded NBR Gasket
CR/SBR Blend
Low Durometer CR/SBR Blend
Non-black CR for Injection Moulding
Hard Rubber Industrial Wheel
High Durometer NBR Masterbatch
NBR/PVC Cable Jacket
NBR/PVC/SBR Blend
Butyl Masterbatch
Butyl Masterbatch, Heat Interacted
Chlorobutyl/NR Blend
CSM CORD Jacket
Non-black Millable Urethane
Some Major Changes
Tempered Water
Power-controlled Mixing

Energy Conservation
Composition of EPDM Elastomers
Variables in EPM and EPDM Elastomers
Average Molecular Weight
Molecular Weight Distribution
Ethylene/Propylene Ratio
Type of Diene
Diene Level
How Processing Relates to Structure and Rheology
Practical Guidelines for Mixing EP Elastomers
Using Internal Mixers
Polymer Composition and Form
Filler/Oil Levels and Types
Cure Systems
Processing Aids
Mixing Process
Mixing Instructions
Fill Factor
Mixing Temperature
Machine Parameters
Ram Pressure
Coolant Temperature
Automation
Machine Condition
Downstream Processing Equipment
Using Two-roll Mills
Summary
Rework
Phase Mixing
Natural Rubber Viscosity Reduction
Measurement of Mixing Efficiency
Special Considerations
Raw Materials
Typical Formulations
Internal Mixing
Mill Mixing
Summary
Accounting Methods
Farrel Continuous Mixer
Operating Principles of the FCM
Commercial Applications for the FCM
Farrel Mixing Venting Extruder (MVX)
Designing the Rotor
Analysis of Dispersive Mixing
3 TECHNIQUES OF VULCANIZATION
Pressureless Vulcanization

Rubber Moulding
Factors of Moulding
Mouldin
Compression Moulding
Transfer Moulding
Injection Moulding
Helicure
Buffed Tread Crumb
Incineration and Pyrolysis of Tyres
Reclaimed Rubber
4 RUBBER VULCANIZATION
Physical Property Tests
Free Sulphur Determination
Solvent-swell Method
Mooney-Rivlin Equilibrium Modulus
Differential Scanning Calorimetry
Determination of Spring Constant
Sulphur Vulcanization
Peroxide Crosslinking
Resin Vulcanization
Electron Beam Vulcanization
Nitroso Compounds
Metal Oxides
5 RUBBER COMPOUNDING
General Compounding Principles
Tensile Strength
Tear Resistance
The Crescent Tear Test
The Hardness of Rubber
Set
Abrasion Resistance
Flex Cracking Resistance
Resilience
Heat Build-up
Temperature Resistance
Tyres
Retreading Materials
Conveyor Belting, Transmission Belting and Hose
Footwear
Rubber Roller
Medical Applications
'O' rings and Seals
Rubber Blends
Master Batches
Choice of Rubber
Fillers

Vulcanizing Agents
Peptizers
Accelerators
Activators
Anti-oxidants
Retarders
Softeners and Plasticizers
Rubber Crumb
Factice
Processing Aids
Special Purpose Additives
Unvulcanized compound properties
Vulcanized compound properties
6 RUBBER RECLAIMING
7 MANUFACTURE OF RUBBER PRODUCTS
Classification
Components
Tyre Building
Parts of a Conveyor Belt
Cover rubber
Manufacturing Process
Finished belt testing
PVC Belting
Steel Cord Belting
Design of Hoses
Hose Manufacture
Braided/spiralled hoses
Testing of Hose
Constructions
V-Belt Manufacture
Main Types of Power Transmission Belts
Preparation of Ingredients
Stability of Latex Compounds
Manufacture of Latex Products
Foaming and Gelling
Vulcanization
Classification and Terminology
Fabric Lined Water-proof Shoes
Canvas Shoes
Micro-cellular Soling
Manufacturing procedure
Types of Mountings
8 LATEX AND FOAM RUBBER
Selection of Raw Materials
Preparation of Raw Materials
Compounding and Design

Maturation
Processing and shaping
Dipped Goods
Latex Thread
Vulcanisation
Hot Air Cure
Hot Water Vulcanisation
Autoclave Vulcanisation
Radiation Vulcanisation
Ultrasonic Wave Curing
Testing of Rubber Products
Packing and Marketing
Conclusions and Recommendations

Manufacture of Latex Foam
Dunlop Process
Mechanism of Gelling
Compounding
Foaming and Gelling
Construction of Moulds
Curing
Washing
Drying
Finishing
Common Defects in Foam Making
Shrinkage
Foam Collapse
Setting
Complete Distortion of the Foam
Protein estimation protocol
Conclusion
9 SILICONE RUBBER
Electronics and Electrical Industries
Silicone Rubbers to Mimic Flesh
Silicone Polymers
Silicone Rubber Elastomers
Reinforcing Fillers
Semireinforcing or Extending Fillers
Additives
Curing Agents
Mixing
Freshening
Moulding
Extrusion
Calendering
Dispersion Coating of Fabric

Heavy-duty Hose

Bonding

Bonding Unvulcanised Silicone Rubber

Bonding Vulcanised Silicone Rubber

Post-baking

Condensation Cure—One-component

Condensation Cure—Two-component

Addition Cure

10 POLYBUTADIENE AND POLYISOPRENE

Polyisoprene

Cyclopolyisoprene

Gel and Branching

Polybutadiene

Isoprene

Butadiene

11 STYRENE BUTADIENE RUBBER (SBR)

Raw Materials

Production of Hydrocarbon Rubber

Manufacture of Emulsion SBR

Vinyl Content and Blockiness

Molecular Weight and Branching

Manufacture of Solution SBR

Property Control

Branching

Blending

Properties

T_g Measurement

Molecular-weight Measurement

Dynamic Mechanical Measurements

Applications of SBR

12 RECLAIMED RUBBER

Whole Tyre Reclaim

Drab and Coloured Reclaims

Butyl Reclaim

Scrap-rubber Preparation

Reclaimed Rubber

Digester Process

Reclaimator Process

Pan Process

Engelke Process

Testing and Evaluations of Reclaimed Rubber

Millroom Operations

Special Strengths Through Reclaiming

Further Advantages of Reclaiming - Applications

Major Uses of Reclaimed Rubber

Automobile floor mat
Semi-pneumatic tyre
Butyl inner tube
Innerliner
Carcass
Applications
Process
Characterisation of Reclaimed Waste Latex Rubber (WLR)
13 NITRILE AND POLYACRYLIC RUBBER
Uses of Nitrile Rubber
Mixing and Processing
Latest Developments
Composition
Raw Polymer Characteristics
Physical Characteristics
Heat, Fluid, Low-temperature Resistance
Applications
Cure Systems
Reinforcing Agents
Plasticisers
Process Aids
Antioxidants
Mixing
Extrusion/Calendering
Compound Storage Stability
Vulcanisation
Bonding Characteristics
Solution Characteristics
Blends
Future Developments
14 RUBBER NATURAL
Agriculture
Exploitation
Latex Composition
Types and Grades
Production
Latex Concentrate
Processing
Chemistry
Physical Properties
Economic Aspects
Applications
15 HARD RUBBER
Ebonite
Hard Resin Rubbers
16 RECYCLING OF RUBBERS

Reclaiming Technology
Surface Treatment
Grinding and Pulverization Technology
Microwave Method
Ultrasonic Method
General Remarks
Use in New Tires
Rubber/Recycled Rubber Blends
Thermoplastic-Recycled Rubber Blend
E. Concrete Modified by Recycled Rubber
Asphalt Modified by Recycled Rubber
Use of Crumb Rubber in Soil

[^ Top](#)

Sample Chapters

[Hide](#) ▼

(Following is an extract of the content from the book)

Mixing Technology of Rubber

INTRODUCTION

This chapter deals broadly with the art and science of mixing rubber. Those unfamiliar with the nuts-and-bolts aspect of the industry may all too readily attribute artistic (or even magical) practice to the exotic ingredients and process techniques involved in manufacturing rubber articles. Others who have experienced the frustration when a composition does not quite meet a required physical property, lacks an anticipated attribute, or processes unsatisfactorily for no apparent reason, only to uncover remedies that are as difficult to explain as the symptoms, they will understand the phrase 'art and science'. These occurrences do not detract from the scientific achievements that have driven the art of mixing to its current level of sophistication.

The goal in mixing is to provide compositions having useful properties and suitable processability with as high a level of consistency as possible. The terms *useful* and *suitable* are determined by the application, for example, what is suitable for a sink stopper might not be suitable for an O-ring. In almost all applications there are criteria for the attributes that characterise whether a composition is suitably mixed; the criteria may vary, but they exist nonetheless. It is almost always the case that these criteria must be met with optimum efficiency, *i.e.*, with the maximum output per expenditure of capital and energy.

In order to understand the reasons for the techniques and types of machinery employed in mixing, one must have some familiarity with raw materials, their physical forms, functions in the compound, and behaviour during processing. Several basic categories of ingredients are usually distinguished.

(a) Rubber or polymer-bales, clips, pellets or powder

(b) Fillers-powder, pellets

- Reinforcing-carbon
- Extending - clay, calcium carbonate, talc

(c) Plasticisers and lubricants-fluids, oils, waxes, process oil, ester plasticisers, processing aids, waxes, proprietary blends, stearic acid.

(d) Miscellaneous additives-powder, pellets, fluids

- Antioxidants, antiozonants
- Colourants
- Release agents

(e) Vulcanising agents and accelerators-

- Sulphur
- Peroxides
- Special ingredients

A knowledge of physical characteristics and forms leads to a certain amount of guidance regarding the most suitable type of mixer. For example, the knowledge that liquid additives need to be mixed into a liquid polymer would direct the technologist to certain types of equipment. But selection of the optimum mixer is not always possible, primarily because of economic factors. The organisation must often make do with what happens to be available; the ingenuity of the compounder lies in his or her ability to achieve specific results with the equipment on hand. On the other hand, given some degree of choice a more appropriate machine is usually available to improve mixing characteristics and, therefore, final properties. Early in the history of rubber compounding, almost simultaneously with Goodyear's discovery of sulphur vulcanisation it was found that kneading or softening the elastomer was useful in increasing its receptivity to incorporation of powders. This is the basis of mixing-masticating the elastomer to make it receptive to other ingredients, yet retaining sufficient stiffness to ensure adequate dispersion. (The more difficult an ingredient is to disperse, the higher the viscosity required during mixing) This balance of mastication without undue shear softening can be achieved through several means.

1. Mixing with close temperature control.
2. Use of a specific sequence for adding materials.
3. In some cases, remixing after cooling (two-pass mixing).

These three considerations apply to mixing with all the most common types of equipment: two-roll mills, internal batch mixers, continuous mixers, extruders or combinations thereof.

MIXING MACHINERY FOR RUBBER

Two-roll Mills

Every mixer must provide two basic functions, both equally important-acceptable dispersion (intensive or dispersive mixing) and high uniformity (extensive or distributive mixing). The equipment used most often by the rubber technologist is the two-roll lab mill-a device for preparing small quantities of mixed compound. This mixing device is usually set for a ratio of roll surface frictional speed of about 1.25:1.

Roll Nomenclature

Diameter (D)	Usually same for both rolls
Face length (L)	Roll length (mill sizes expressed as $D \times L$)
Roll gap	Distance between rolls
Sank size	Material sitting above gap
Banded roll	Roll which material follows
Front roll	Roll on operator's side
Slow roll	Roll rotating at slowest speed
Fast roll	Roll rotating at fastest speed
Friction ratio	Roll speed ratio
Separating force	Resultant force exerted by material in roll gap

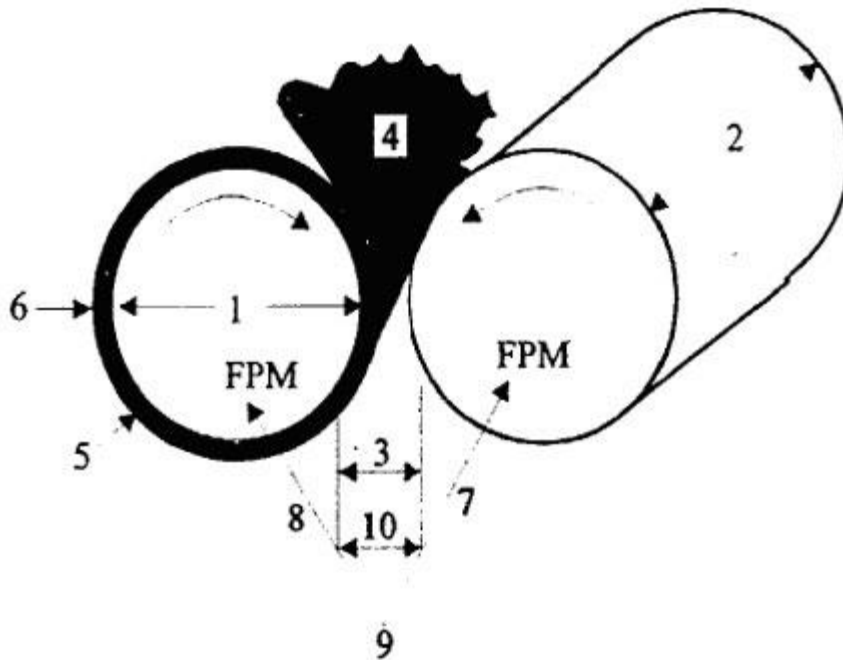

The rolls are bored to permit cooling or heating the gap between the rolls adjustable within a range related to roll diameter. The mixing procedure is relatively standard. The operator places portions of elastomer on the mill, kneading the sample by multiple passes through the gap, until sufficient reduction in stiffness permits it to wrap and adhere to one roll. The gap is adjusted so that a reservoir of elastomer is always rotating above the nip. This reservoir is called the rolling bank. Rolling is rarely observed when the polymer has only limited elastomeric character at the milling temperature. In such cases the reservoir may flop about or break into discrete sections. This behaviour may often be corrected by a different choice of mill temperature on one roll or both, sometimes merely by using a different nip setting.

Powders are now added into the gap with frequent pan sweeping to recover increments which drop through. Process oil or plasticiser is also added usually after pan of the filler content has been incorporated. Only then does the mill operator begin to cut the rubber from one side of the mill, passing it to the other side, to cross-blend the batch. At the conclusion of mixing (usually determined by the judgement either of the operator or a supervisor) the batch is cut from the mill for cooling and storage. A major advantage of mill mixing is the high shear developed at the mill nip, this breaks up agglomerates and drives incorporation of ingredients. Furthermore, the massive surface exposure imparts good cooling, thereby maintaining the stiffness of the compound. And due to the roll friction ratio the rolling bank imparts further high shear.

The disadvantages of mill mixing usually far outnumber the advantages and may be listed as follows-

1. Length of the mixing cycles

2. Dependence on operator skills
3. Dust and dirt levels that are typical
4. Difficulty in standardising subjective procedures
5. Difficulty in controlling batch to batch uniformity.

Mills are used more in forming and breakdown applications than in actual mixing except for addition of curatives to pre-mixed masterbatch. The most common ratio of roll speeds in the past was 1.25:1, with the slower of the two rolls usually on what is most frequently the operator's side (often called the 'front' roll). Recent investigations have shown that the temperature rise of rubber on a two-roll mill is directly related to the sum of the speeds of two rolls. Therefore, whether the sum reduced by slowing the faster of two rolls (a change of friction ratio), or by reducing the speed of both rolls (maintaining the same friction ratio) the result is a reduction in rubber temperature build-up. Mills built in recent years have had lower total speed ratios closer to 1.1:1 and the fast roll at the front. In addition to improved processing of a broader range of elastomeric compounds, many such mills have also featured drilled rolls, permitting better temperature control and leading to easier compound release.

Internal Batch Mixers

The Banbury internal mixer was originally manufactured to replace the two-roll mill. The original nomenclature indicated the approximate number of 60" mills that a specific Banbury size could equal in output. The basic design of the machine includes two rotors that operate at a slight speed differential. The rotors are non-interlocking. Mixing or shearing action occurs between the rotors and the sides of the mixer and between the rotors themselves. The mixer is top loaded through an opening large enough to accommodate bales of elastomers (as well as the other ingredients). Pressure is exerted on the batch using a ram which closes the feed opening. Discharge of the batch occurs at the bottom of the mixing chamber. The rotor design is such that material in the chamber is constantly being displaced, corresponding to the cross-blending action of the mill operator cutting the batch on a two-roll mill. The compound is subjected to the shearing action of the rotors against the sides and the action of the rolling bank between the rotors.

The mixing chamber sides and the rotors are copied to maintain a high rate of shear during the mixing process. Improved cooling has been one of the most significant changes in modification of Banbury mixers over the years. The currently used cooling passages, called drilled sides impart an ease of heat transfer never before obtainable. In fact, the heat transfer efficiency of drilled-side mixers is so great that too much cooling can occur, leading to inefficiency when mixing certain types of compounds. This is corrected, and mixing generally much improved, by the use of a closed-circuit coolant tempering system. This system is used to dial in the proper temperature, optimising the degree of heat transfer and complementing the viscosity of a specific compound.

As with the two-roll mill, the sequence of ingredient additions is critical. In the case of the high viscosity elastomers, the polymer is usually added and masticated before the fillers are added; then the plasticisers and softeners are finally introduced. If the particular compound contains no curatives it is then discharged at an appropriate predetermined temperature. If the compound is a single-pass thermosetting composition, the curatives and accelerators are also added and the batch discharged at a lower temperature to prevent scorch (premature curing). The criterion for completion of the batch is often mixing to a specific temperature. Other criteria include elapsed time, and total power input into the batch. A combination of these observations is commonly used to judge the end-point and related to further processing of the batch during fabrication or to observe properties after vulcanisation. The selection of rotor speeds, mixer size and the extent of materials handling automation are all related to the demands of the specific sector of the rubber industry. At one extreme there is the massive quantity of compound mixed by tyre manufacturers, where most compounds are two-stage mixed (masterbatch and final) using high speed, automated materials handling equipment and large mixers. On the other hand, many custom compounders and mechanical goods manufacturers (who have a large number of recipes) prefer lower speeds and smaller machines and they have too great a variety of materials for totally automated handling. In many cases their compounds are mixed in a single cycle to reduce handling and inventories.

The major advantages of the internal batch mixer are as follows:-

1. Highly reproducible cycles
2. Minimum dependence upon operator skills
3. Large capacity and high output
4. Relatively short mixing cycles
5. Potentially clean factory operations.

But there are some disadvantages, compared to mill mixing:-

1. More rapid temperature rise in mixing
2. More time needed for cleaning equipment
3. Much higher initial investment.

Continuous Mixers

Compared to thermoplastics, continuous mixing of rubber compounds is a relatively new concept. The machinery available ranges from simple single screw extruders to twin rotor, multistage machines. All of these mixing extruders place a common demand upon materials; the ingredients need to be available in a free-flowing form capable of being continuously weighed and metered to the mixer. The continuous mixer receives the compound ingredients and

disperses them to the extent needed to develop target physical properties. The required extent of mixing can be directly related to the ease or difficulty experienced with the same compound in batch mixing. Ingredients such as powders and liquids usually involve no undue problems in accurate continuous metering. The polymer, on the other hand, is often supplied in bales, requiring grinding or pelletising to provide a form suitable for continuous feeding. Recent demand has caused some polymer producers to offer a range of elastomers in pellets or powder form, thereby improving the option of continuous mixing. The advent of powdered rubber could revolutionise mixing. The advantage is that most or all of the distribution could be accomplished by using low power high intensity blenders. The resultant blend could then be fed to a simple relatively low horsepower mixer to masticate the compound and render it useful for fabrication. Vulcanisate properties often appear to depend upon a specific level of work input during mixing. In general, it is probably not significant whether this work is provided by a sequence of several machines or by a single mixer although the properties of all polymeric compositions are path-dependent to some degree.

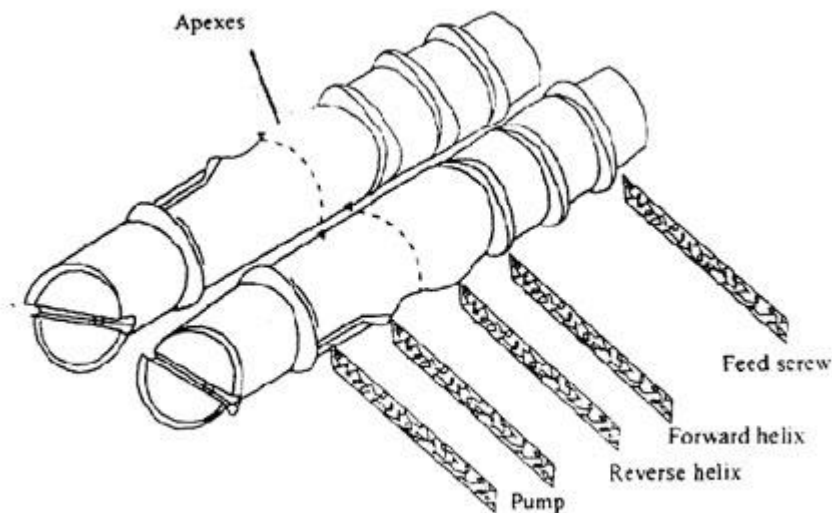

With the advances that have been achieved in raw materials and product handling systems for batch mixers, it is sometimes hard to draw a clear line between batch and continuous systems. In developing the most useful configuration, the following considerations are suggested:

Advantages of continuous mixing

1. Very high product consistency is possible.
2. Automation level are highest.
3. Minor formulation changes are readily feasible.
4. Minimal floor space and ceiling height is required.

Disadvantages of continuous mixing

1. Supply of raw materials in free-flowing form may be costly.
2. Clean-up from compound to compound may be very extensive.

Development of the Banbury Mixer

The Banbury internal mixer was introduced to the rubber industry in 1917; the first mixers were supplied to Goodyear for mixing tyre compounds. For many years these mixers bore numerical designations for different sizes. These numbers approximated the quantity of 22" X 60" in mills that a specific Banbury mixer could replace. Soon after the first internal mixers were introduced, increases in speed, power and ram pressure made this relationship no longer meaningful.

The earliest mixers had the same basic fundamentals of operation as those which are in service today. A ram is necessary to push raw materials into the mixing chamber, two counter rotating rotors perform the mixing action, and a door at the bottom discharges the completed batch to a secondary piece of machinery. Improvements continued to increase the value of the design for mixing applications, despite changes in materials and in expectations.

The F-series Banbury mixers were introduced during the early 1970s. Unlike the earlier mixers, these F-series machines carried designations for each model which defined chamber volume. The F-series Banbury mixers not only introduced many new mechanical improvements, but were designed with the user in mind. Loading and discharge features and maintenance features were designed to emphasise the mixing capabilities of the machine rather than loading, unloading and maintaining.

When the F-series mixer hoppers were enlarged to accept bales and slabs of rubber more readily, the hopper door angle was steepened to assist in more rapid introduction of material to the mixing chamber. The junction between the hopper and the mixing chamber was provided with replaceable throat wear plates. These permit maintenance in an area subject to significant wear because of the action of the ram, well ahead of wear to the chamber. In the latest models, replaceable wear plates have been extended further into the hopper to increase the stiffness of the assembly.

The end-frames have been significantly strengthened and the access to the dust seals has been enlarged to assist maintenance or replacement. Within the mixing chamber the rotor end-plates have been converted to a one-piece design, eliminating occasional contamination associated with older, two-piece designs. This design also prevents the end-plate being dislodged from its fitting, reducing the incidence of mechanical failure. Rotor journals are now tapered, eliminating the need for bearing sleeves. Overall manufacturing tolerances have been reduced, lowering vibration and yielding longer useful service life.

The wall thickness of the sides has been increased by nearly a factor of 2 over older models, in response to the higher loads experienced with modern mixing procedures. The dual-circuit cooling design and the size and location of the bored cooling channels provide highly improved

heat transfer. The discharge area has been significantly increased to permit more rapid batch discharge, reducing the interval between batches and adding to productivity. The toggle latch locking mechanism for the drop door has been made more positive in action but with lower moving parts, requiring less maintenance.

Rotor volumes are measured by immersion displacement, chambers' volumes by measurement and calculation. It is entirely feasible to convert an older D-series Banbury to the improved F-series equivalent. In many cases, the existing drive and hopper can be incorporated in the conversion. As shown in Figure 3, intensive mixing-the breakdown of agglomerates leading to a high level of dispersion- occurs by the action of the rotor against the side of mixing chamber. Extensive or distributive, mixing is accomplished by the continuous moving and shearing of the batch by the rotors; it occurs mainly between the rotors and the ram, and is influenced by the geometry of both. Intensive and extensive mixing must be considered, not only in machine design, but also with regard to mixing procedures.

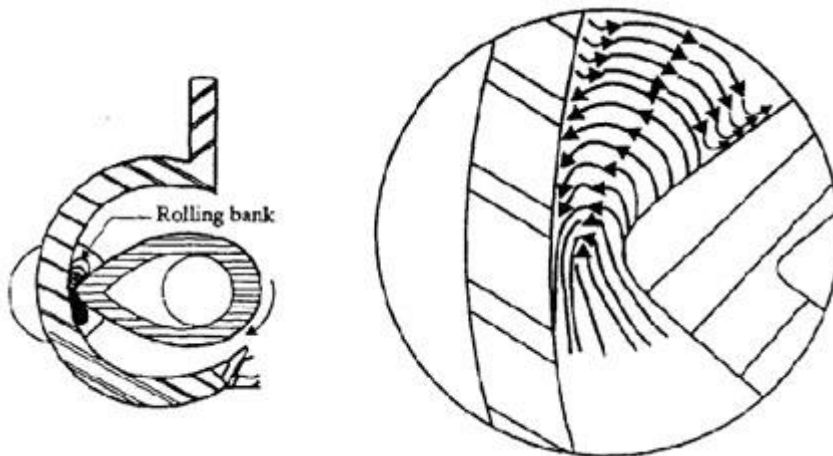

Operating Variables

The major variables in mixer operation are ram pressure, charging procedure, rotor speed, batch size and coolant temperature. With a properly designed and well-maintained mixer, some selection of these variables will optimise the mixing of almost every rubber compound yet devised.

Ram Pressure

The major purpose for application of pressure to the ram is to drive the raw materials into the mixing chamber and to prevent their upward exit during mixing. Increasing ram pressure beyond this point is often found in practice, from a folkloric belief that it will speed the mixing action or otherwise improve it. In fact, it usually has the opposite effect. Too high a pressure can impede rotor action needed for extensive mixing.

The proper seated ram position is shown in Figure 4. The most popular ram configuration, now considered standard, is the single V-bottom.

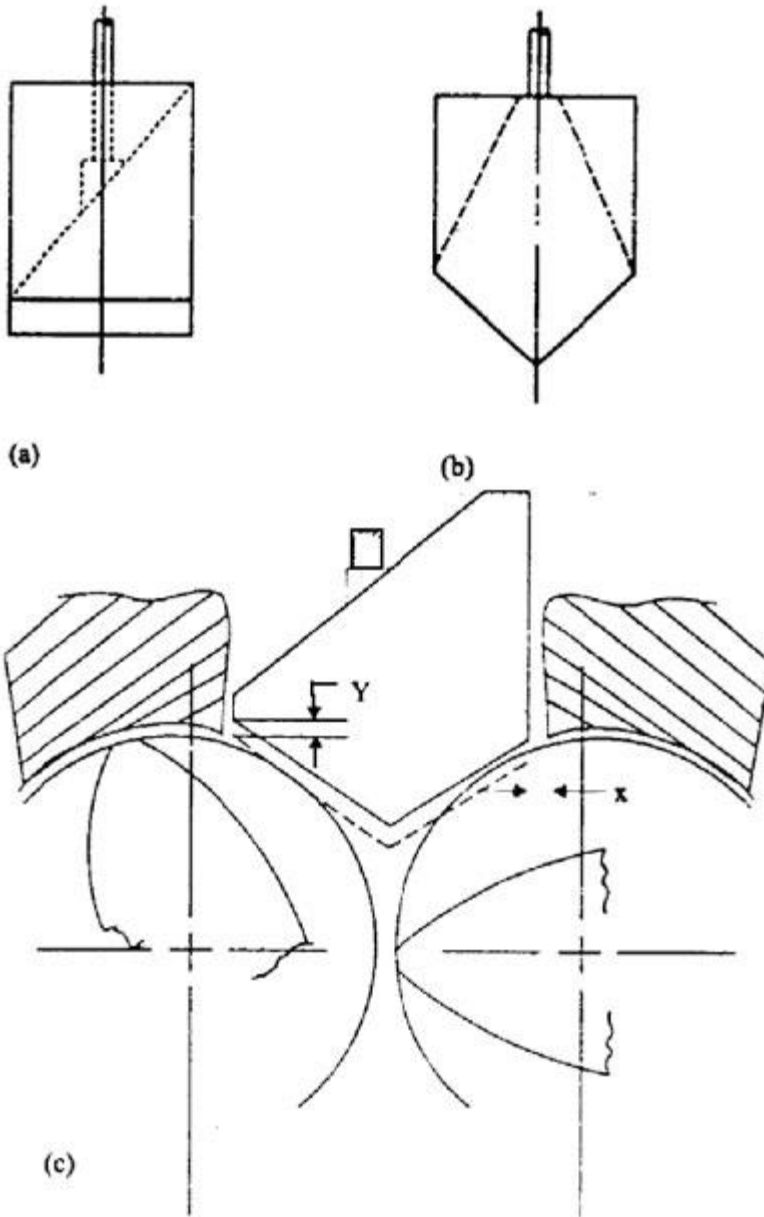

Somewhat less popular is the double, gable V-bottom which facilitates addition of powder or liquid ingredients over the ram while it is in the down or mixing position. This procedure is not recommended as it increases wear and maximises hang-up of the compound from one batch to the next. It is in exactly the same category as dumping the batch with the ram in the down position. Nevertheless, both procedures retain popularity with those more interested in saving a few seconds of mix time than in machine life or batch to batch contamination. The flat-bottomed ram may still be found in older machines.

Because of the variation in air cylinder diameters, ram pressure should not be obtained from a pressure gauge on the supply line, but measured directly on the batch. Such data can then be transferred from one mixer to another. High ram pressure is useful in charging the mixing chamber, but a lower pressure is more desirable during the actual mixing. This has led to the development of multiple-ram pressure control systems. Two or three zones are pre-set with individual regulators to specific pressure levels. This may be automated or controlled by the mixer operator. It can include provision for relief of ram pressure if certain limits on power draw are exceeded, or even if the change in power draw indicates a likelihood that such limits may be reached. This is particularly useful in moderating power surges with upside-down and sandwich mixes. It also provides the means for staying below certain power plateaus that, in some locations, strongly affect plant utility costs.

The importance of ram pressure and position led to the development of the automatic sensing device shown in Figure 5. By means of its output graph the ram position indicator can provide a good profile of the mixing action and a guide to proper batch size. Typical profiles are shown in Figure 6. Here, three batches of the same compound are mixed to a total elapsed time T. The desired ram action is shown in Figure 6(b).

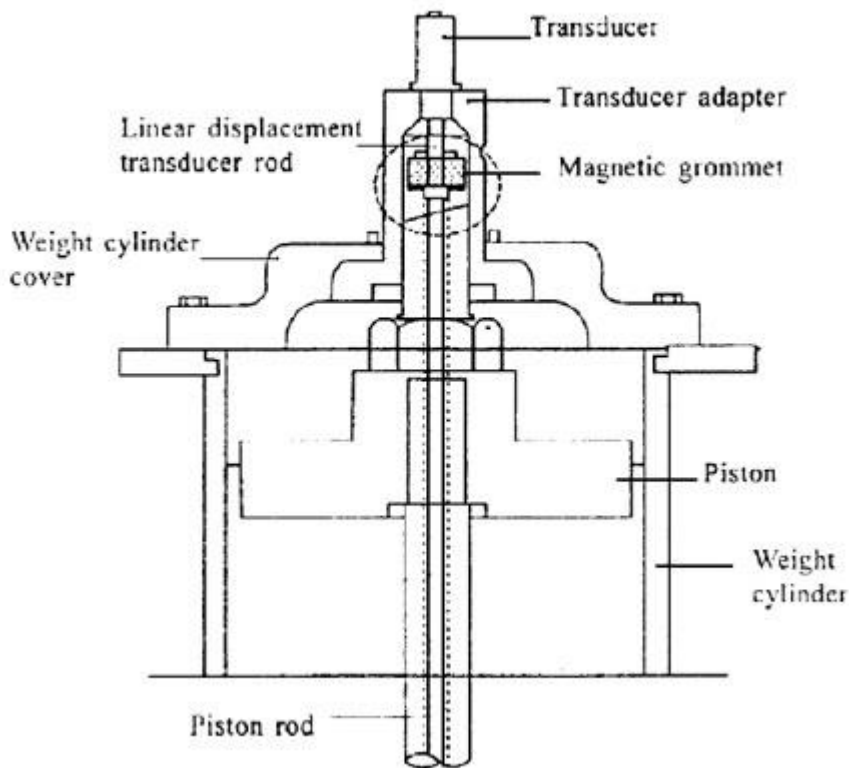

This is followed by a longer period of reduced ram action corresponding to distributive and dispersive mixing. Figure 6(a) shows an oversized batch of the same compound. Almost to the end of the batch, the mixer struggles to incorporate the excess of ingredients. Dispersion and uniform distribution will not be optimum if the ram does not reach a fully seated position in the

first third of the mixing cycle. Figure 6(c) depicts the same batch below optimum batch size; the ram seats almost immediately; distributive and dispersive mixing are strongly impeded.

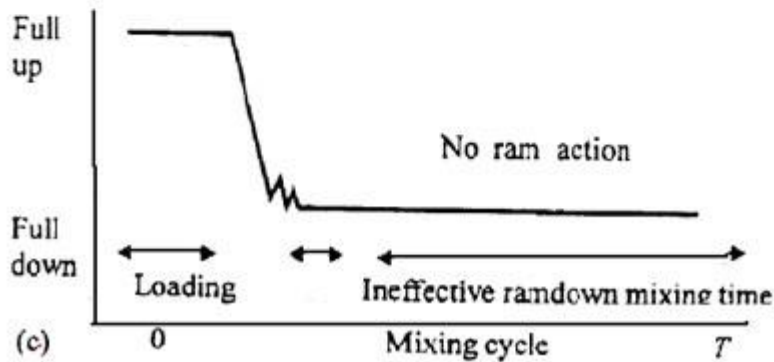
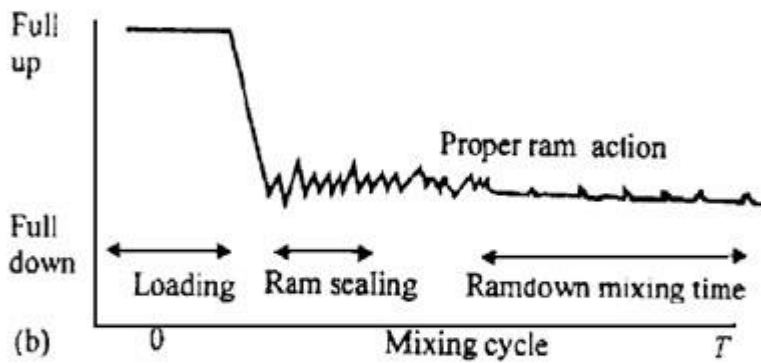
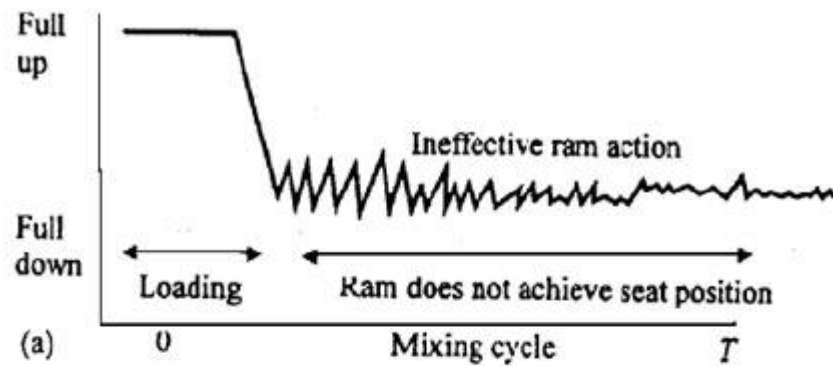

At optimum batch size, ram displacement charts can be used to fine tune the ram pressure programme so as best to approximate Figure 6(b). Besides this, batch to batch charts can spot equipment malfunction and aid in diagnosing improperly weighed batches.

Rubber Compounding

INTRODUCTION

Compounding is the development of rubber mixes which will effectively perform in service. At the same time, the mixes should be capable of being processed in the factory without much difficulty and at minimum cost. Chemically speaking, a rubber "compound" is not a compound, but is merely a mixture of rubber and compounding ingredients, ready for vulcanization. The simplest of all compounds, rubber plus vulcanizing agent, is of little use in most applications. Since it is the basic structure for most compounds, we have to consider how it can be compounded with reinforcing agents, anti-oxidants, and plasticizers to give the best combination of properties for a particular application.

General Compounding Principles

The scope of compounding consists of specifying the type and amount of various ingredients in a mix, the manner of mixing, the processing of the mixed compound, and the method and details of vulcanization. This essentially covers the requirements of end-use and service properties, processability, and cost. The three major decisions to be made by the compounder, considering all these factors in designing a compound, are connected with the choice of rubber, the level of reinforcement, and the type of vulcanization system to be employed. In general, these factors determine cost, mechanical and visco-elastic properties, resistance to degrading influences, processability, and special requirements such as flame resistance, low temperature flexibility and non-toxicity for application in contact with food-stuffs.

VULCANIZATE PHYSICAL PROPERTIES AND THEIR SIGNIFICANCE

Physical tests of quality are a means of measuring some fundamental physical property or attribute of a rubber compound. Service testing or product testing is more often than not connected with product design and manufacture. In practice, the failure of rubber articles occurs mainly by tearing, abrasion, or dynamic fatigue arising from crack propagation. Therefore, physical tests are often required for development of new materials or products or in developing new engineering uses of rubber. However, there is generally poor correlation between laboratory tests (particularly the static tests) and product performance. Despite this, laboratory tests have been developed due to the advantages of low cost, quick results, and the ability to compare many compounding variables primarily for screening purposes.

For many years, physical tests on vulcanizate properties such as tensile strength, hardness, abrasion resistance, resilience, tear, compression, cut, and crack growth have been standardized in the rubber industry. We shall consider the individual tests and their significance. The tests have the following uses: (1) designing compounds to meet service conditions; (2) investigating product or process failures; (3) quality assurance of compound batches; and (4) quality control of raw material.

Tensile Strength

This is defined as the force on unit area of original cross-section which is required to break the test specimen, the condition being such that the stress is substantially uniform over the whole of the cross-section. The elongation at break is the maximum value of the elongation expressed as a percentage of the original length. The value of tensile stress (force/unit area) required to stretch

the test piece from the unstrained condition to a given elongation (say 100 or 300 or 500%) is called the modulus or, more accurately, "tensile stress at a given strain".

Hooke's law is obeyed by metals, which undergo practically only elastic changes of shape below their yield point. However, in the deformation of rubber, we must differentiate between (a) an elastic deformation, (b) a plastic deformation and (c) an extension or residual deformation. The E modulus for metals is always the tension for an imagined elastic extension of 100%. In practice, this amounts to only 0.1% and then passes from purely elastic extension into plastic deformation. Thus for steel, the E modulus is 2,000,000 kg/cm², i.e. under this stress, the extension would be 100%. However, the modulus of rubber is not a constant, as in the case of metals.

The modulus of rubber is not the ratio of stress/strain as used by engineers. It merely signifies the coordinates of a point on the stress/strain curve and is loosely used as a synonym for stiffness. Contrary to engineering practice, test results on rubber have no absolute meaning as they depend on the conditions of the test. Rubber specimens undergo gross changes in shape when stressed, unlike other high strength engineering materials. Rubber tensile machines can be used for various tests such as: (a) for the determination of tensile strength and elongation at break and (b) the determination of tensile stress values at given elongations. These are the so-called "modulus" values.

Physical properties can differ length-wise and cross-wise on a section of rubber compound due to anisotropy. In the direction of calendaring, tensile strength is high and extensibility is low; across, the strength is relatively low and extensibility high. This phenomenon will be pronounced in the case of short-fibre reinforced rubber compounds.

Tensile test specimens can be tested at room temperature with standard Schopper-type machines of 0.5-5 KN capacity. The lower grip of such a machine moves at constant speed, while the upper grip is connected with a pendulum type dynamometer. The specimen is strained by a uniform movement of the lower grip, to which one end of the specimen is attached. The other end of the specimen is held by its upper grip. The pendulum is displaced from its normal position by a pull on the specimen and the amount of displacement indicate the force. The pendulum is lightly ratcheted to a notched sector so that after the specimen breaks, the pendulum and the pointer which is geared to it will remain stationary at the maximum load.

The pendulum moves with varying (usually increasing) angular velocity, i.e. there is angular acceleration. When this occurs:

$$FR = Mg D + I (dw/dt)$$

where F is force exerted by test piece, R radius of the dynamometer load, M mass of pendulum, I its moment of inertia, D horizontal displacement of mass, and angular acceleration of pendulum.

The pendulum-type machine is widely used by reason of its simplicity and lower cost, but it is subject to error mainly due to the pendulum inertia and the unavoidable friction in the pendulum bearings. The machine must be used within the range of 15-85% of its maximum force to reduce inaccuracy. Some machines have a constant rate of traverse of the lower grip (usually 50 ± 5 cm

per minute), while others have a gear box to provide a range of speed. Movement of the upper grip occurs during deflection of the pendulum. This may cause variation in the straining rate of the specimen. Other machines have a heating chamber in which tests can be carried out at temperatures from approximately -18°C to 100°C .

The specimens used take the form of dumb-bells cut out from products. This design of a satisfactory test specimen takes into account two main problems in tensile testing. First, the difficulty of holding the rubber securely without any slipping, and second, the avoidance of high local stresses in the test piece which would cause premature rupture at the grips. The broader portions at the end of the dumb-bell are held in self-tightening grips which automatically tighten as the thickness diminishes during stretching. The broader portions are joined to the narrower central portion, i.e. the actual test section, by curved "shoulders" to avoid stress concentrations. The true length of the test specimen cannot be measured by recording the distance between the grips; this is done by marking the central portion of the piece with two parallel crosslines, the volume of rubber between the marks is regarded as being stretched uniformly. The dumb-bell pieces are punched from press moulded sheet, taking care to ensure that the cut be as clean as possible. For a complete determination of the force-extension curve, a record of the total course of the extension up to the point of break, taken with the help of an autographic recorder is required. Alternatively, readings at two or three load values, corresponding to the elongations of 100, 200, 500 or 700% may be taken.

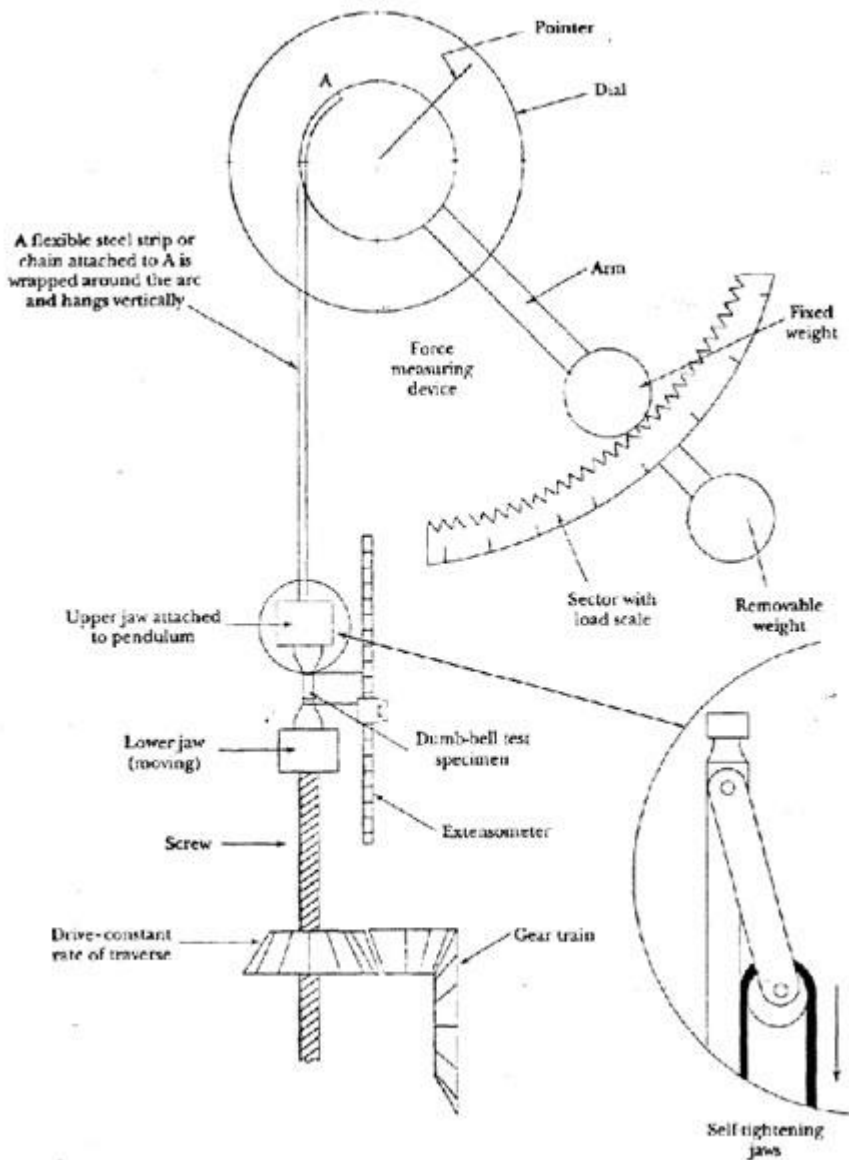

Electrical-force measuring machines have been developed to overcome the inertia of the pendulum-type testing machine. In these devices, the load on the upper grip results in the deformation of a light but perfectly elastic metal ring. The extent of this deformation is then measured by electrical means. These instruments have a greater range, and force-extension graph or read out devices. There is negligible movement of the upper grip, and inertia effects are avoided. Most of them also have facilities for reverse motion to enable a retraction curve to be drawn, or for cycling tests. They also have cycling, automatic zeroing of load and extension outputs, and fast cross-head return, making them particularly suitable for repetitive quality control-type testing.

Tensile tests are almost invariably used either to indicate the quality of rubber vulcanizate or for purpose of quality control in production, but are seldom if ever, used in component design.

Tensile strength in itself bears little relation to product service, as rubber is not normally used at such high elongations that there is a danger of failure due to tensile rupture even after moderate ageing.

As a service test, tensile strength tests are valueless but for many purposes of comparison, they are extremely useful. High tensile strengths coupled with a reasonable elongation at break can only be obtained with high quality rubber mixes and for this reason tensile strength is very often included in specifications, e.g. conveyor belt cover rubber. They are also useful for determining the curing characteristics of compounds—the cure condition giving the highest tensile strength being widely adopted as optimum cure. Deterioration of rubber on ageing can be followed by the drop in tensile strength. Effect of many compounding ingredients as well as that of pigment dispersion can be decided by tensile strength tests. Finally, as a control test, it is invaluable since any mistake in mixing or processing giving inferior product is indicated by a drop in tensile strength.

Unlike most other engineering materials, rubber can be compounded to give a wide range of elastic modulus values. This enables a product of fixed dimensions to be made in a variety of stiffnesses. Stiffness of rubber is equivalent to $(\text{modulus} \times \text{area}) / \text{thickness}$. In most applications, the modulus of rubber is more important in compression, shear and torsion, than in tension. In compression, the shape factor plays a significant part. Empirical curves have been compiled to illustrate this feature. Modulus measurements show less variations than values taken at rupture and thus, more reliable. Modulus is a useful property to measure as the compounder and designer generally have a reasonable idea of what level of modulus is most likely to suit the applications, e.g. it is generally thought that heat build up is less with low modulus casing compounds since they work under constant stress. However, modulus evaluations can be misleading because it is measured at an extremely low speed of deformation. It is believed that at high speed "dynamic" modulus may be different.

Elongation at break gives some indication of "chunking" tendencies in tyres. A high elongation is a good feature.

Ageing tests on tensile samples are traditional rather than technically useful. They can indicate disadvantages in cracking if the modulus increases rapidly on ageing, but ageing tests do not help in sorting out anti-crack anti-oxidants.

Tear Resistance

The measurement of tear strength of rubber from an initiating nick is carried out by tensile type tests using a specially shaped test piece which concentrates the stress in the region of the nick. This property is important in a number of products, e.g. tyre treads, tubes, cable sheaths, hose, etc. A very rough indication of resistance to tear may be obtained by nicking a piece of rubber and tearing by hand. The test which is now universally accepted employs a crescent shaped specimen cut by means of a die and press from a specially moulded slab of rubber. Differing test piece shapes are also used, but they tend to give diverging results.

The Crescent Tear Test

A test piece in the shape of a crescent is punched from thin rubber sheet. A small cut is made on the inside curve of the specimen to an accurate depth of 0.5 mm by means of a special cutter employing a razor blade. This specimen is then stretched in a tensile testing machine and the minimum force required to tear the test piece across the width of the uncut portion is then measured and reported.

The tear strength is dependent upon the width and thickness of the test piece and the test result is expressed as the load necessary to tear a specimen of standard width and thickness.

$$\text{Tear strength} = L \times t1/t2$$

where L is the maximum force noted, $t1$ is the thickness of the standard test piece (2.5 mm), and $t2$ is the measured thickness of the specimen tested.

An important difference between tear testing and tensile strength testing is that while the applied force is uniformly distributed over the cross-section of the test piece in the latter, in tear testing, it is concentrated at the base of the nick. Tear values are influenced by the sample size and shape and therefore, care must be taken to simulate tear phenomena in service.

Compounds with high tear resistance such as those loaded with carbon black, give a jagged tear path. When tear resistance at elevated temperatures, i.e. hot tear is required, a heating chamber enclosing the specimen should be fixed to the tensile testing machine.

The tear resistance at elevated temperatures is important where the product may have to function at such temperatures in service and also where the product may have to be stripped hot from a mould which tends to hold it. At elevated temperatures, some synthetic rubbers are significantly weaker than others in tear resistance.

The Hardness of Rubber

Hardness is defined most simply as 'resistance to indentation'. The hardness of rubber has been widely used as a control test and many product specifications quote hardness as a guide to the type of compound required. In many cases, this may be the only property specified. Hardness tests may indicate the state of vulcanization or degradation in use. Compound hardness is greatly determined by the type and amounts of reinforcing filler used, softeners used and by the use of crosslinked resin system. The hardness value best suited for a product will need to be determined by practical trial or rig test.

Hardness measurements in rubber are different from those on metals as they are related to modulus determination at low strains and are not the permanent indentation made by a point. The indentation depth is converted into International Rubber Hardness Degrees (IRHD), the scale of which ranges from 0 (infinitely soft) to 100 (infinitely hard). The usual range of hardness covered is 30 to 90 IRHD. Shore A and IRHD, although not exactly equivalent, are the same within the limits of experimental error.

Hardness tests can be divided into two types; (a) accurate and reproducible standard laboratory testing, calling for a dead-load hardness tester and (b) routine checking, calling for a portable, spring-loaded, pocket type instrument.

Tests which are based on the measurement of the indentation of a rigid ball into the rubber test-piece under specified conditions use 'dead-load' instruments. The usual test is done on flat test-pieces 8-10 mm thick, atleast 9-10 mm from the edge. It may be possible to take test-pieces of much smaller dimensions from many components (2 ± 0.5 mm), and a 'micro-test' is then done with the result expressed in 'standard micro-hardness' which is approximately equivalent to the standard hardness.

Dead-load type hardness instruments are more reliable than spring loaded instruments because the applied force is controlled, whereas with the latter the pressure of the indent or foot will vary from operator to operator. The dead-load type instruments must be carefully levelled so that the spindle is substantially vertical. They are, therefore, more suitable for laboratory use.

Wallace (or Shore) hardness is defined as the resistance against the penetration of a body of specified shape applied under a specified spring loading. Spring loaded instruments are portable and thus more suitable for checking actual products. Their scales must be frequently checked as the springs are liable to incorrect setting, fatigue or elastic drift, and the indentors prone to wear or damage. The time of load application is not carefully controlled, and this can lead to errors. All spring loaded pocket type instruments are sensitive to applied pressure, and are therefore, subject to variation in results when used by different operators.

The special features of the different types of hardness measuring instruments are given in Table 1. The special feature of the indentors used in different hardness instruments are shown in Fig. 2.

Special Features of Hardness Measuring Instruments

<i>Type</i>	<i>Dead-load</i>		<i>Spring loaded instruments</i>	
	<i>Hardness instrument</i>	<i>Microhardness testers</i>	<i>Wallace type</i>	<i>Shore type</i>
Indentor	Ball 2.38 ± 0.01 mm diameter	Ball, 0.4 mm diameter	Hemispherical needle $5/64$ in mm diameter	Frusto conical needle 0.79 mm diameter face
Load	2.294 N/5.68 N	0.00814 N, 0.1537 N	Depends on spring force 2.65 N	Depends on spring
Foot	5mm diameter 0.02 N/mm ²	3mm diameter 0.02 N/mm ²	-	-
Measurement of	Dial gauge International	Dial gauge IRHD-samples less than 4	Dial gauge Wallace hardness	Dial gauge Shore "A"

indennation unit	Rubber hardness Degree (IRHD) Level surface required Suitable for laboratory use	mm thick Level surface required Suitable for laboratory use on small samples	units Portable Suitable for checking products	and shore "D" Portable Suitable for checking products
------------------	---	--	---	---

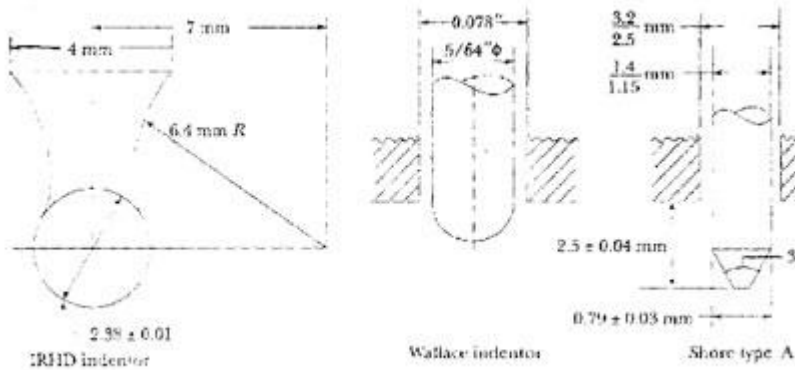

Set

Set is the amount of residual displacement in a rubber article after a distorting load has been removed irrespective of whether the load was in tension/compression/shear.

Tension set A dumb-bell specimen is stretched to a definite elongation and allowed to stand for a specified time. The tension is released, and after a definite time, the specimen is again measured. Increase in length calculated as a percentage of the original length is the tension set.

Generally, the lower the set, the better. One factor which influences the set is the state of cure. Under-vulcanized rubber has a high permanent set.

Compression set A moulded cylinder of rubber, used as the specimen which may be compressed at normal or elevated temperature to a pre-determined (in terms of percentage) height, is measured after compressing for a period of 24 hrs. This test is useful for rubber components which have to function under compression, e.g. rubber heels, compression buffers, etc.

Abrasion Resistance

The resistance to abrasion is an important property since it determines the useful life of a number of rubber products. However, abrasion tests are just as problematical as the other physical property tests and do not allow exact forecast of service behaviour.

The subject is extremely complex as the service conditions under which different products are abraded very considerably. When we consider such widely differing products as tyres, footwear, flooring and conveyor belts, it is evident that no single laboratory machine can cover the service conditions of these articles. Two main types of laboratory abraders are described below:

The DIN abrader consists of a cylindrical drum covered with emery paper. The specimen holder which contains the test specimen exerts a specified force on the emery paper. The test block is traversed slowly along the length of the cylinder, so as not to pass repeatedly over the same abrasive surface. Volume loss of the test specimen, before and after testing, is found out and the "abrasion resistance" compared against a reference sample.

Abrasion resistance = Volume loss of standard specimen/Volume loss of test specimen × 100.

The PICO abrader (ASTM 2228) abrades by means of knives of controlled geometry and sharpness. Standard rubbers are used for comparison and for checking the knives.

Laboratory abrasion test is an accelerated test. The different machines are all very useful in the laboratory to give a quick indication of abrasion resistance, but all of them have certain fundamental faults. The abrasive surface tends to become plugged up by the abraded particles. Abraded particles are also very much larger than those under actual service conditions. Although temperature has a large effect on wear rate, it cannot be controlled at the contracting surfaces during the test. The tests do not reproduce impact abrasion. Frequently, they are useless in comparing polymers, or for real development work with curatives, anti-oxidants or plasticizers.

Flex Cracking Resistance

Many rubber products must withstand repeated cycles of flexing without failure. During flexing small cracks may appear on the surface and these grow larger and deeper until they become large enough to cause failure. Therefore, information of flex cracking is important when designing compounds for tyre treads, belt covers, boot upper, etc.

"Flex cracking" has been defined as the occurrence and growth of cracks in the surface of rubbers when repeatedly subjected to a cycle of deformation.

Several laboratory test machines are available but as with abrasion resistance, these may not give a true assessment. It is, therefore, necessary very often to subject actual products to service type tests. The two popular machines are De Mattia machine and the Flipper machine.

De Mattia Machine The machine most widely used for soft rubber vulcanizates up to 70 IRHD is known as the De Mattia machine. This consists of a row of fixed grips and another parallel row of reciprocating grips which grip a moulded specimen. One of the clamps oscillates at high speed by a crank mechanism and by adjustment, the distance between the clamps and the stroke can be varied to give different degrees of flexing. The grips are set so that they approach each other to a distance of 18 mm and separate to a maximum of 75 mm at a rate of 7500 mm/min. The test piece is a flat strip, with a moulded transverse semicircular groove on which the strain is concentrated when the test piece is bent by bringing its ends nearer together. The cracking observed is compared with a series of descriptions and photographs contained in the standards.

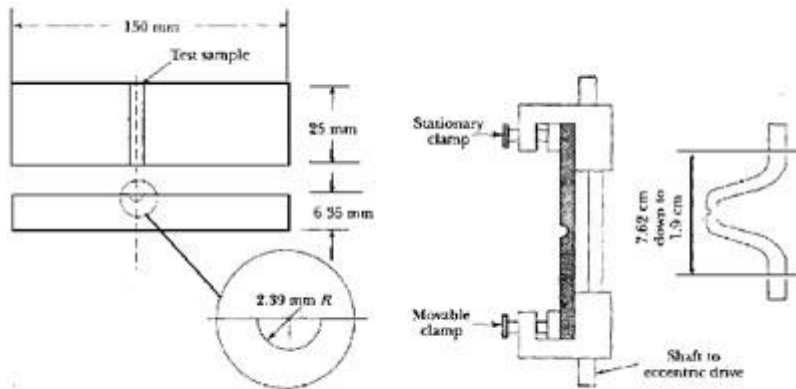

The Flipper Machine This machine consists of a rotating disk on which specimens mounted in spots protrude from the periphery. These specimens are flexed by striking idler rolls. The specimens are flat mouldings having a ribbed portion at one end and grooves similar to those of the De Mattia test piece. The rotation or face ends are bent by contact with the idler rolls at the grooves. After test, the assessment and grading are done as described for the De Mattia machine.

Both the machines are compact and can be enclosed in a cabinet having elevated temperatures, ozonized air, or other means of accelerated ageing. The cut growth test differs from that of flex cracking in that the test piece is first punctured, at the base of the groove, by a chisel shaped tool with a blade 2 mm wide. The length of the cut is measured before and after various periods of flexing, the test result being the numbers of flexing cycles for pre-determined increases in this length.

Fatigue tests Fatigue may be defined as the deterioration in physical properties and eventual failure of rubber when repeatedly subjected to a stress well below its ultimate tensile stress. The onset of fatigue in rubber is characterized by the appearance of a series of cracks on the surface, which enlarge on repeated deformation, and eventually cause failure. Sudden section changes in the stressed/strained parts, or the rubber going through zero deflection (relaxation) in a plus-minus straining cycle will lead to fatigue failure of rubber.

For the dynamic testing of soft rubber, "fatigue testers" are used in which the life of the material is recorded, depending on the actual conditions, in revolutions, minutes or load cycles. The test results may be expressed either as the rate at which a cut extends, or as the number of cycles required to cause complete failure of the test piece. The test basically aims to establish on order of merit of materials and for comparison purposes, machines are designed to test many samples simultaneously. Test specimens may have a cut specially made to study cut propagation. The results are sensitive to the stress cycle used, particularly if this passes through zero. As the tests are run in air, it is probable that ageing effects will play an important part in the failure processes, so that these tests are often used for the evaluation of protective agents. Fatigue testing for service prediction is not easy and requires considerable efforts to identify the important test variables in the design and interpretation of the fatigue test.

In tyres, flex cracking occurs in the side walls and in the base of the grooves of the tread. Tyre failures, however, may occur due to cut growth and fatigue, accompanied by rise in temperature (heat build up) due to flexing.

Resilience

This property is one of the outstanding features of rubber. It shows the ability of a rubber vulcanizate to return the energy used to deform it. Low resilience values correspond to a higher internal friction and to a larger heat build-up on repetition.

The simplest form of resilience test involves the dropping of a steel ball into a rubber specimen and noting the height of rebound. Various rebound pendulums such as the Schob, Lupke, Dunlop, and Goodyear-Healey are in use.

The Healey pendulum springs from a predetermined height and rebounds to a height determined by the resilience of the rubber specimen.

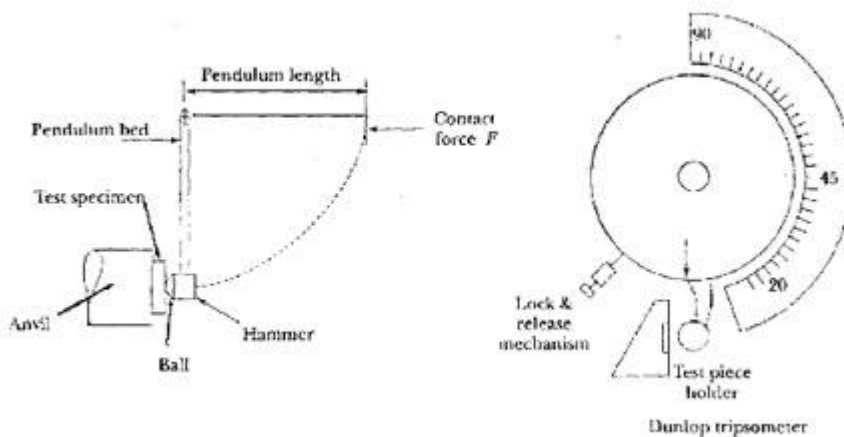

The Dunlop triposometer takes the form of an out of balance metal disc revolving on virtually frictionless bearing and which acts as a slow moving pendulum. The test-piece is placed against a rigid support so that it receives a blow at its centre. A circular scale is provided for measuring the angle of displacement. The measured quantity is the angle to which the disk rebounds after the hammer strikes the specimen.

Resilience is lower when rubber is over or under vulcanized and is also reduced by such fillers as carbon black. The higher the reinforcing properties of the black, the lower the resilience. Resilience is influenced by the state of cure and can, therefore, be used as a test for degree of vulcanization.

The rebound resilience test is a "single point" determination of damping characteristics. The picture obtained thus does not necessarily agree with the behaviour under high frequency dynamic load change. For complete characterization of damping curves, other methods are used. Usually, these use cylindrical rubber test pieces which are set in oscillation in an axial direction.

Heat Build-up

In the Goodrich flexometer (ASTM D623), the cylindrical rubber specimen is set in oscillation between anvils, one of which is connected to an eccentric and the other to a lever which can be loaded. The tests are carried out in a thermostat and the increases in temperature are measured by a thermocouple inserted into the anvil attached to the lever. The amplitude of the oscillations and the load can be varied. The effect of carbon black on hysteresis and heat build up is evident in flexometer tests. With a higher loading of carbon black, a temperature increase results, and the measured temperature increases linearly with the loading. As the degree of vulcanization increases, heat build up decreases.

Temperature Resistance

Exposure of rubber to low temperatures results in stiffening and eventual fracture as deformation occurs. The change is reversible and independent of the time of exposure, unless permanent damage has occurred due to deformation. (At high temperatures, however, the effects are irreversible and substantially time dependent).

Low temperature capability of rubber is determined by the Gehman Test, which compares the torsional modulus of rigidity at low temperatures with that at room temperature. The resistance of rubber strips to bending, twisting, and impact at low temperature, from -20°C to -80°C , and sometimes lower, is determined by several methods. The methods generally used are Brittleness test, Brittleness temperature by impact. Young's modulus in Flexure and Gehman torsional apparatus for determining flexibility.

In the Gehman torsional apparatus, the cooling fluid is usually a mixture of solid carbon dioxide and methanol, and the test-piece is maintained at the required temperature at zero deflection in the cooling fluid, between a lower, fixed clamp and an upper clamp which is free to twist. The test piece is twisted at approximately constant speed through 90° , and the load required to twist the upper end of the sample through 90° is noted. There should be minimum tension in the test piece, so that it is allowed to change in length as it twists, and minimum friction in the bearings. The cooling fluid must also not affect the rubber. The rigidity modulus (at a particular temperature) is calculated from the expression.

$$G = \frac{L}{Wt^3} \frac{K}{\pi} \frac{T}{\theta}$$

where G is the rigidity modulus, L length of sample, t thickness of sample, W width of sample, θ angle turned through is 90° , and K factor to indicate second moment of area of the sample.

The results are frequently expressed in a graphical form as shown in Fig. 5.

Heat resistance of rubbers is substantially affected by the presence of atmospheric oxygen, ozone, and contact with certain fluids, resulting in thermo-oxidative ageing. The physical properties of a rubber may also change if it continues to cure at elevated service temperatures by, for instance, the presence of uncombined sulphur. Volatile ingredients may be driven off by heat, resulting in a reduction in volume and an increase in the hardness of the material. Immersion of

the rubber in a liquid excludes the effects of oxygen, but an increase in temperature may result in a change in dimension due to combined result of the swelling of liquid, absorption, and shrinkage due to extraction of plasticizer on other ingredients. Service temperatures recommended for liquid applications are likely to be significantly higher than those which would be appropriate to dry heat conditions.

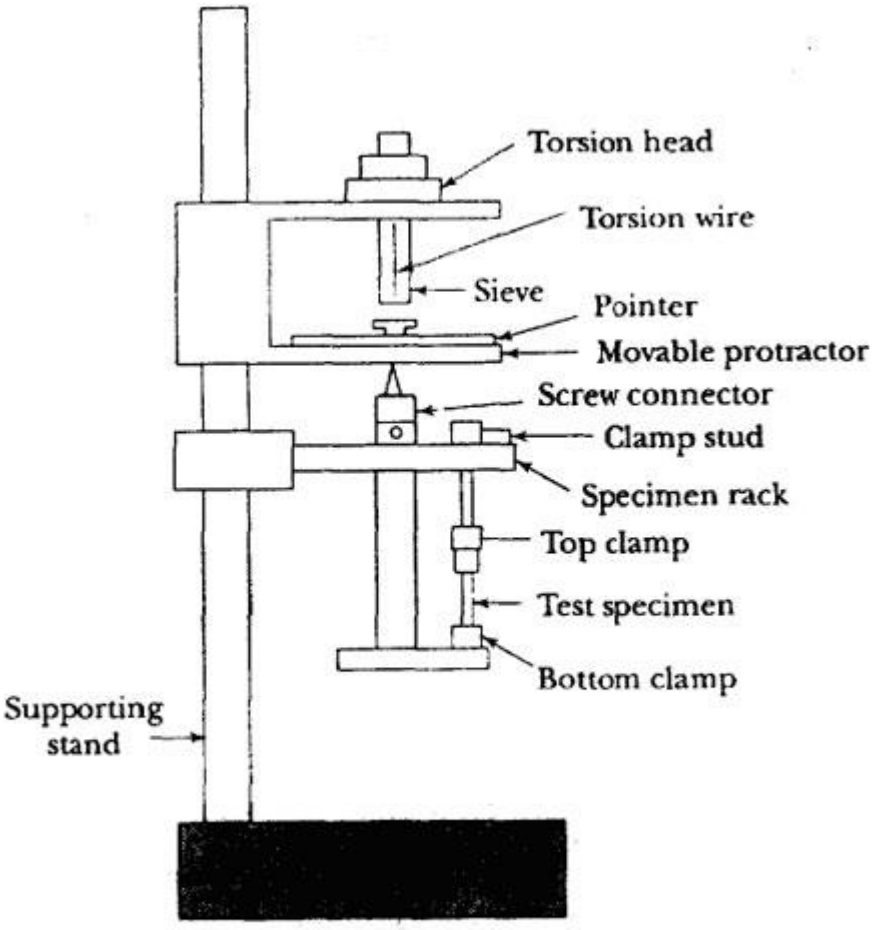

(a)

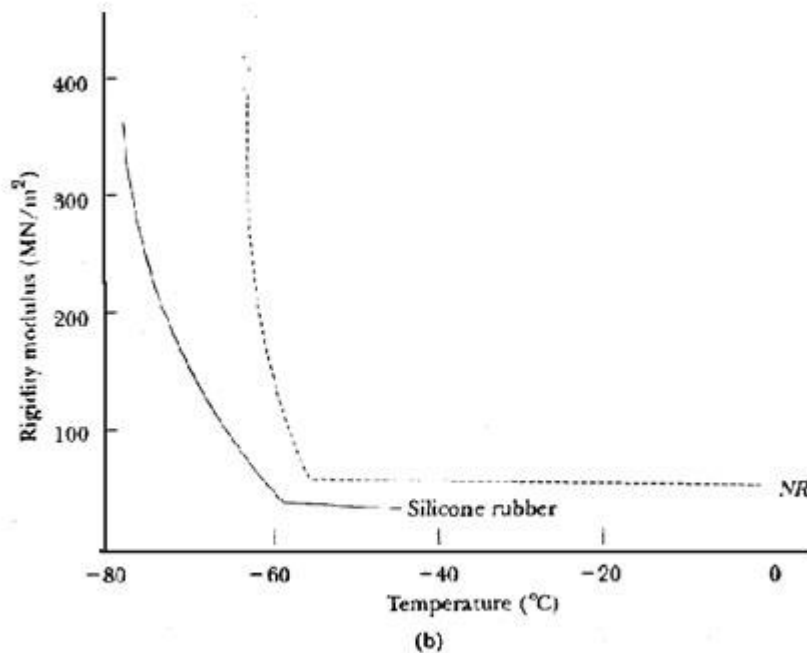

COMPOUND PROPERTIES DESIRED FOR DIFFERENT RUBBER COMPOUNDS

Tyres

Different types of compounds are used for tread, side wall, casing, and beads. Tyre tread is the wearing surface and with the sidewall it protects the casing against damage. The compound must, therefore, be resistant to abrasion, tear, cracking, chipping, weathering, and heat ageing. Certain treads must be conductive. White sidewall or coloured side walls may also be used for some classes of tyres. Certain special applications, e.g. low temperature service in the Arctic or Siberia, requires good low temperature flexibility. Cheaper compounds with non-reinforcing fillers may be acceptable for treads such as for cycle tyres as the service conditions are less severe.

The tread must be cool running for durability. These requirements are met best with the use of two different compounds selectively distributed in the tread, i.e. a cap/base construction. The cap compound provides the desired wear and traction characteristics while the base compound is highly resilient and cool running. This combination reduces the tyre running temperature at the thickest portion of the tyre. Sidewall compounds, made separately from tread, require protective agents for resistance to heat ageing, flexing and ozone.

Casing compounds must ensure a good bond with tread and with the cord. They must be adequately heat and fatigue resistant and cool running. Bead compounds must be hard, bond well to the wire, and give the finished bead the desired degree of rigidity and flexibility. They should be heat resistant and must insulate one strand from another.

Tube compounds should have high extensibility, good air retention properties and should be heat resistant.

Flaps protect the inflated tube from damage from the rim surface in tubed tyres. The flap compound should be adequately hard and heat resistant.

Curing bags are used to pre-shape the green tyre and press the tyre against the mould surface through application of internal pressure and heat. The compound should be heat resistant as steam or hot water is circulated through the bag to heat up the green tyre from the inside.

Retreading Materials

Tread rubber is used for retreading worn out tyres. The compound must have a long shelf life in addition to good abrasion and heat resistance. For industrial trucks, bulky moulded objects, solid tyres, are used in slow moving vehicles carrying heavy loads. The compound must be hard, resilient, and relatively cheap. They are usually black and made of low grade material.

Conveyor Belting, Transmission Belting and Hose

Cover compounds are subject to rubbing abrasion of sand and hard materials. They must be abrasion resistant with good ageing and weathering properties. Heat resistant compounds will be required for application where hot substances, e.g. quenching cinders are carried. Oil resistant compounds are required for conveying oily or greasy substances.

Transmission belting carcass compound must be cool running and flex resistant as these belts have to transmit power at high speeds over relatively small pulleys. V-belt base compounds must be hard with good heat and flex resistance and cool running.

Hose compounds may be for lining, insulation, or cover. Lining compound protects the carcass from the deteriorating influence of the material to be carried. The compound must be resistant to deterioration from these influences, e.g. steam, oil, and chemical resistance. A hose lining is designed to withstand effects such as swelling, chemical attack, or abrasive wear, which might result from the material flowing through the hose.

Insulation compound bonds the outer layers of braiding and provides resistance to rupture when pressure or suction is applied. Compound should be soft and of low viscosity.

Cover compound protects the carcass from deterioration in service or storage, and should be abrasion and degradation resistant. A hose cover is designed to resist influences which might operate outside the hose. Usually, these are different from the internal influences and so the cover compound is usually different from that of lining.

A motor car radiator hose, carries water at low or moderate temperatures and without pressure. It must be cheap and have good heat ageing properties (being near the engine). As it must be produced in large numbers, it must be capable of fast extrusion and cure as well as of low volume cost. It must also have sufficient strength to resist splitting at the ends when fitted.

Footwear

The main requirements for rubber sole compounds are abrasion and flex resistance, hardness, traction, shape retention, and adhesion to the upper. A range of hardness 35 Shore A to 95 Shore A, and specific gravity from 0.40 (for sponge) to 1.65 (for slab soling) is in use. Quality and cost may vary according to the requirements for specific uses. Typical sole compounds use natural rubber with hard clay and white fillers, the types and amount adjusted to vary hardness and abrasion resistance. The shoe sole must have reasonable flex or cut growth resistance and also stitch tear resistance when it is attached to the upper by stitching with thread. High styrene resin with silica filler may be used in blend with natural rubber/white fillers to achieve superior processing and abrasion resistance to replace leather soles. Heavy duty work shoes utilize clay and silicate pigments. Carbon blacks are used only in low proportion in order to avoid (floor) contact staining.

Foxing compounds must have good extrusion or calendaring properties and must have good tack to both the sole and upper. These compounds include high grade natural rubber SMRL with whiting and titanium dioxide to adjust colour.

Rubber heels come in several varieties of sizes, thicknesses, and qualities for original equipment or replacement heels. They are compounded for attractive finishing characteristics, and for ease of attachment to automatic attaching and finishing machines. The compounds are loaded with hard clay, whiting and silicate fillers. Heel bases may be used between the heel and the sole in some shoes. These are economic, filled compounds. Reclaim (with carbon black) may be used if the part is not exposed to wear.

For hard rubber compounds used as top lifts or spike heels, nitrile rubber, reinforced with phenolic resin, may be used as polymer base. Ground walnut shell flour, silica, wood flock fibre etc. may be used in specialized applications to impart 'traction' or anti-slip characteristics.

For footwear compounds, whiting is the predominant filler for rubber boots, tennis shoes, gyro shoes, duck shoes and casual footwear where the elastomer is natural rubber. Shore A hardness of 50 to 70 are usually obtained in these compounds. Clays may be used with whiting to upgrade the compound quality or with silica fillers to reduce cost. Zinc oxide is normally used as an activator. Titanium dioxide and red-oxide are used as colouring pigments. Talc is used as an inert-filler similar to whiting for economic reasons.

The rubber compound for microcellular soling must be sufficiently soft to allow easy expansion during vulcanization. It usually contains 30-40 parts of high styrene resin. Reinforcing fillers like precipitated silica, calcium silicate, aluminium silicate, and clay are used. A blowing agent of the DNPT type is used to produce nitrogen during cure.

Rubber Roller

The rubber compound must have good metal to rubber bonding and building tack to facilitate plying up unvulcanized sheets.

Medical Applications

Rubber products for use in medical (surgical or pharmaceutical) applications are usually governed by some form of governmental specification. The selection of compounding ingredients for these applications should be done with care to ensure that they are physiologically inert or harmless.

'O' rings and Seals

For an external application, the 'O'ring is usually stretched over the piston into a groove where it will initially be at a maximum stretch of 8%. The section will reduce because of the stretch and on assembling the piston into the cylinder bore, the section will be compressed in order to attain the necessary sealing characteristics. Stress relaxation will occur when the section is under constant strain for a prolonged period and compression set will be observed over a period. For example, in a reciprocating application on a piston head, the 'O' ring will be pushed back and forth in its housing and may extrude out on both sides coupled with spiral twisting.

Squeeze-type seals operate by distorting under a compressive load, and the hardness selected must be sufficiently high to ensure adequate retention of sealing pressure. This can often be achieved by incorporating one or more plies of fabrics rather than by increasing the hardness of the mix which might adversely affect other properties. Dimensional effects on contact with liquids can be adjusted to achieve a small positive swell, capable of maintaining sealing efficiency, by compensating for seal wear and compression set. The choice of compound will depend on the effects of the fluid with which the seal will be in contact, the operational temperature, and mechanical conditions such as pressure, relative velocity and abrasion.

The basic design of a rubber compound must take note of three requirements: (1) the end-use and the service requirement of the product; (2) trouble-free processibility of the compound during manufacture; and (3) volume cost and availability of raw materials. Various types of rubber and compounding ingredients are specified in compounds to meet service requirements, processing requirements, and volume cost.

COMPOUNDING INGREDIENTS

Rubber: In India, as in other natural rubber growing countries, NR will most certainly be used in cases where the rubber compound does not have to withstand high temperature, direct sunlight or ozone, and where it does not come into contact with oils, solvents, or chemicals known to attack it. Synthetic rubbers, which are superior to natural rubber in these specific properties, are used depending upon the conditions of service of final product. The typical applications are listed below:

- **SBR:** Used as general purpose rubber.
- **Butyl rubber:** Low permeability, so used in tubes and inner liners. Good chemical resistance, so used in tank linings. Curing bags and bladders are made of resin-cured butyl to give good heat resistance.

- **BR:** Good abrasion resistance and fatigue resistance. So it is used for tyre treads (in blends with NR and SBR), solid tyres, conveyor belts, shoe soles, golf balls, and anti-vibration mountings. BR has higher resilience, but as tear resistance is poor, it has to be compounded with higher black and oil, which lowers the resilience and such BR treads generate more heat than do treads based on NR.
- **Nitrile rubber:** Good oil and solvent resistance.

Most polymers (including NR) can be "oil extended" and with higher black loadings, economic compounds can be developed.

Rubber Blends

Rubbers are often blended or copolymerized with another polymer, or chemically modified so as to enhance basic properties. Blends will be expected to have properties and price combining those of the individual components and thus, provide both technical and economic advantage. The addition of small amounts of a suitable rubber may improve properties such as oil or ozone resistance or improve processing behaviour. However, it generally does not improve the heat resistance.

Blends of emulsion and solution polymerized rubbers often give processing difficulties. The different rubbers being blended may have differences in viscosities and curing characteristics which may lead to processing difficulties and the final vulcanizate properties of the blend being inferior to the levels attainable with the individual rubbers. The properties adversely affected by non-compatible rubber blends include tensile strength, set, low temperature behaviour, and covulcanizability. Due to the reactivity difference in the blended phases and/or diffusion of vulcanizing agents (which are usually polar) from the less polar to the more polar phase, consistency of blending may be difficult to achieve under factory conditions. Inadequate covulcanization then leads to unfavourable mechanical properties such as inferior tensile properties, and poor dynamic behaviour.

Master Batches

A master batch is a mixture of rubber with one or more compounding ingredients in definite but higher concentrations than those in which they normally occur in a complete rubber mix. It is used for accuracy and efficiency in compounding, in order to avoid the addition of small amounts of accelerators, anti-oxidant, pigment etc.

Choice of Rubber

Natural Rubber (NR): Natural Rubber gum stocks can be compounded with tensile strengths, which are quite high compared to those of non-crystallizing rubbers. This is associated with the tendency of natural rubber to form crystallites when it is strained. Tensile strength can be further increased within limits by increase in crosslink density or at constant crosslink densities by addition of carbon black. Compression set can be reduced by raising the crosslink density, but tensile, fatigue, and ageing properties are reduced slightly. In natural rubber compounds, silica is often added to provide high tear strength without a prohibitive increase in heat build-up. Semi-

efficient vulcanization systems can give improved resistance to reversion and compression set at elevated temperatures. Soluble eV systems give low creep, stress relaxation, and compression set at elevated temperatures. They are not suitable for service at low temperatures for prolonged periods. The urethane crosslinking system gives vulcanizates with good resistance to high temperature ageing and suitable for arduous conditions. Air permeability of natural rubber compounds can be improved by use of natural rubber/chlorobutyl blends.

The use of gum natural rubber mixes is popular in articles such as gloves, surgical goods, toy balloons, elastic thread, and crepe soles.

From the processing stand point, natural rubber grades can be broadly divided into two groups: (a) viscosity stabilized grades such as SMR CV and SMR GP and (b) non-viscosity stabilized grades like RSS 1, RSS 3, SMR 10, and SMR 20. The viscosity stabilized grades do not require premastication prior to mixing and, therefore, mixing energy requirement is reduced.

Styrene Butadiene Rubber (SBR): SBR is generally marketed at a lower viscosity than NR and this permits its use in rubber compounding without premastication. Mechanical or chemical peptizing is not required. While most properties of SBR are comparable with NR, in some respects like heat build up, tack, and gum tensile strength, SBR is inferior to NR. But addition of resins and reinforcing fillers adequately improves the latter properties.

Owing to its irregular structure, SBR does not crystallize. A reinforcing filler is needed to achieve good physical properties with SBR. The best reinforcing agent is carbon black. Non-black fillers give very inferior properties in SBR to those they would give in a corresponding natural rubber mix. Abrasion resistance and resistance to degradation under heat are better for SBR than those of NR. SBR is less active chemically than NR and is thus slower curing, requiring more accelerators than NR. Scorch problems are less likely to occur with SBR than with NR, especially in black-filled compounds. SBR is compatible with NR, BR, EPDM NBR, and CR.

The effect of sulphur: accelerator ratio on the sulphur crosslink distribution is similar for SBR as for NR. In general, a lower sulphur level, and a higher accelerator level, is normally employed for SBR cure systems. In SBR, the use of eV systems tends to reduce resistance to flex fatigue cracking.

Emulsion SBR's are used alone as well as blended with BR or NR to improve the properties. In comparison with other diene rubbers, higher filler (75 pbw of carbon black) and plasticizer (20 pbw or more including the quantity contained in OE SBR) contents may be used. In addition to the cost benefit, the technical advantages in usage in car tread compounds include improved wet and dry grip while maintaining good abrasion resistance. Generally, N220, N375 or N339 carbon blacks and aromatic and naphthenic process oils are the preferred types.

Cold SBR is used for lighter duty tyres and in belting, hose, shoes, moulded goods, and other mechanical goods. Its low resilience compared to NR in black loaded compounds restricts its use in those tyre treads where a high heat build up is tolerable. SBR is not suitable for truck tyre treads, nor for elastic thread for golf-ball manufacture.

Anti-degradants are usually added to SBR to provide protection during service. Tack can be improved by the addition of tackifying resins or by blending with natural rubber. Generally SBR compounds are fabricated into composite articles with the use of natural rubber based solutions or insulation layers to obtain satisfactory building tack. Oil resistance of SBR can be improved by blending NBR into SBR based compounds. Plasticizers of the petroleum and coal-tar types are used to improve factory processing and to reduce costs.

Solution SBRs are generally more expensive than the emulsion types and are used in specialty applications; they consist of rubbers with different styrene and vinyl levels both of which raise the T_g and hence the wet grip. This is particularly useful in high performance radial car tyres and motor cycle treads.

Polybutadiene rubber: High cis BR is used in 20-30 parts along with 70-80 parts of NR in tyre treads. It is mainly used in truck tyre treads because of its high abrasion resistance and low heat-build-up. Tyre treads with NR/BR blends or SBR/BR blends give improved tread wear and reduced groove cracking. It is also used in the manufacture of mechanical goods and as a modifier for plastics to improve impact resistance.

Generally, BR is compounded with other non-polar elastomers. BR has limited compatibility with polar elastomers such as NBR (generally approximately 25% rubber hydrocarbon). Blends of BR are used partly due to the poor processing behaviour of polybutadiene as a homopolymer. BR does not respond to mastication and it does not band well on a mill and produces extrusions of rough appearance. It is generally advisable to mix all compounds containing high proportions of BR in internal mixers.

Curing of BR may be achieved by using conventional sulphur systems activated with metal oxide soaps (usually zinc oxide and stearic acid). In comparison with NR, BR requires less sulphur, but marginally higher accelerator levels, to achieve similar levels of crosslink density. Anti-degradants and accelerators are the same as for NR and SBR.

Acrylonitrile butadiene rubber (NBR): NBR does not strain-crystallize and without reinforcing fillers, NBR vulcanizates have poor tensile strength and low tear initiation resistance. Therefore, it is usual to have reinforcing fillers like carbon black or addition of phenolic resins or PVC to improve tensile strength to values which may be even higher than those obtained with NR. Very high hardness compounds can be prepared by using PF resins and NBR/PVC blends. With reinforced NBR vulcanizates, although the tear resistance is lower than for NR compounds, the fall off with higher rates of deformation and at higher temperatures is less than that for NR. NBR shows less abrasion loss than NR.

The incorporation of 30 pbw PVC into NBR compounds results in improved weather resistance and high resistance to swelling. The presence of PVC, however, produces stiffer compounds with lower resilience and inferior low temperature properties. To achieve optimum results, complete gelling of PVC with NBR at 160°C or higher temperature in the presence of an effective PVC stabilizer, such as a metallic soap type vinyl stabilizer, is necessary.

As NBR is susceptible to ozone attack, suitable antiozonants and waxes are to be added. NBR/EPDM blends (70/30 or 80/20 ratio) have a better ozone resistance than NBR compounds.

The heat resistance of NBR can be further enhanced by the use of semi-eV and eV cure systems, low sulphur, or sulphur donor systems. Plasticizers of low volatility should be chosen for heat stable compounds. Because of its strong polar properties, NBR is compatible only with polar plasticizers (DOP, DOS, DOS, etc.), i.e. esters of carboxylic acid or phosphoric acid.

NBR has low permeability to gases, this again depending on the ACN content. Generally, non-staining or slightly staining stabilizers are used in manufacture of NBR. The high polarity of NBR also influences its compatibility with certain compounding ingredients and non-polar rubbers. NBR is not compatible with SBR and BR. Good adhesion between NBR and textile can be achieved with NBR lattices or 50 : 50 blends of NBR and VP lattices in RFL dips.

NBR is a semi-conductor which can be made conductive (10⁴ Wcm) by addition of FEF and acetylene blacks. Anti-static compounds may be prepared by addition of plasticizers for use in textile coats and aprons. NBR and NBR/PVC blends are used extensively as cable jacketing materials and portable electric cord.

The low temperature flexibility of NBR can be improved by the addition of adipate (DOA) or sebacate (DOS) type of plasticizers.

Isobutylene-isoprene rubber (IIR): Butyl rubbers, unlike many other polymers, do not break down on mastication or during the normal mixing process. The compound viscosity can be controlled by selection of the raw polymer grade, carbon black type and loading, oil type and loading, etc. Relatively high loadings of paraffinic or naphthenic oil are employed for typical butyl applications such as tubes or body mounts.

Tensile strength is highest in pure gum stocks, and increasing amounts of fillers generally reduces tensile strength. 50-100 phr carbon blacks (GPF or FEF) are added in practical compounds, and sometimes 100-150 phr of mineral fillers such as hard clay, platy talc, and silicas are also added. The recommended plasticizers are highly saturated materials of relatively low polarity, e.g. hydrocarbon oils, waxes, etc. "Heat treatment" procedures in which butyl and carbon blacks are subjected to high temperature (160-200°C) for at least 2-3 min mixing in the presence of "promoter" such as polyac (DuPont) or nitrol (Monsanto) generally give improved vulcanizate mechanical properties.

Butyl vulcanizates have high damping and this is more pronounced at lower temperatures. The maximum level of ozone resistance can be achieved when the lowest unsaturation grades of butyl are vulcanized to the highest possible state of cure. Plasticizers reduce ozone resistance. Excessively high-carbon black or light-coloured filler loadings should be avoided. Protective agents are not usually necessary but wax or EPDM can be employed to advantage.

Butyl vulcanizates are not serviceable in continuous contact with hydrocarbon oils and solvents as gross swelling will occur. However, butyl is resistant to polar solvents and vegetable/animal oils.

Strong acids and bases do not attack butyl nor do strong oxidizing or reducing solutions. However, concentrated nitric or sulphuric acids cause degradation. In compounding for minimum swell, the factors of greatest importance are high filler loadings, high reinforcement and maximum state of cure. Chemically sensitive fillers- for example, calcium carbonate, in a compound for use with mineral acids-must not be used.

The weathering properties of black butyl vulcanizates are outstanding. To protect non-black butyl compounds from sunlight, it is necessary to use adequate loadings of high opacity pigments, e.g. 15 phr Titanium dioxide or 45 phr zinc oxide.

The inertness of the polyisobutylene chain causes butyl rubber to be outstanding in resistance to heat and oxidation. However, low sulphur or sulphur donor systems with more thermally stable crosslinks show better effects on ageing than conventional sulphur cures. Resin cures are extremely stable towards heat and oxidation and these vulcanizates are preferred for high temperature service.

For general purpose insulation compounds, butyl rubber of low unsaturation grade with low sulphur and calcined clays (90-150 phr) or talc for low moisture absorption and high resistivity are selected. Whittings, calcium carbonates, and soft clay are used in lower voltage applications.

Butyl rubbers, unlike many other polymers, do not break down on mastication or during the normal mixing process. Relatively high loadings of paraffinic or naphthenic oil are employed for typical butyl applications such as tube and body mounts. Compound viscosity is controlled by selection of butyl grade, carbon black particle size and structure, total filler and oil (plasticizer) loading, ratio, etc.

Mixing of butyl rubber compounds: Equipment which is used for processing diene rubbers must be thoroughly cleaned before it is used for butyl to avoid the possibility of contamination and delamination.

Internal mixing is preferable for efficient mixing of butyl compounds. The open mill mixing procedures are not generally suitable for butyl because of inherent high nerve, shrinkage, and resistance to breakdown, which preclude the formation of a mill band except under very specific conditions.

In internal mixing, close attention must be paid to batch weight (generally 10-15% higher than for NR/SBR to ensure full ram pressure during the mix), loading sequence, prewarming of rubber, black addition in stages, etc. As with other polymers, one or two stage mixing cycles are employed with butyl. Where mixing temperature exceeds the safe processing limit, curatives are added in a later stage.

Heat treatment of butyl rubber compounds is carried out by mixing a rubber/filler master batch at high temperature in the presence of a promoter such as dinitrosobenzene. This results in good carbon black dispersion and in better dimensional stability in extrusion and calendaring processes.

There are five basic systems which are used for vulcanization of butyl rubber compounds (quantities in phr, approximate):

- Sulphur 1.0, MBTS 1.0, TDEDC 1.5;
- Sulphur 1.5, MBT 0.5, TMTD 1.0;
- Sulphur donor, DTDM-2.0, TMTDS-2.0
- Resin methylol phenol curing resin with halogenated polymers; and
- Quinone dioxime cure; Red lead 5.0, p-quinone dioxime 2.0, stearic acid 1.0.

Sulphur cures: These are widely used in general purpose butyl compounds in conjunction with zinc oxide activation and (because the crosslinking sites are few), a combination of primary and ultra-accelerators. Stearic acid is not necessary as an activator, but is usually added as a process aid, i.e. as a mill release agent in soft butyl compounds; added late in the mixing cycle, stearic acid helps prevent sticking on the internal mixer drop mill.

Resin cures: These are used when maximum heat resistance is required, e.g. in tyre curing bags and bladders. Resin-cured butyl shows outstanding resistance to both dry heat and steam and can be compounded to give very low compression set. Heat-reactive, oil soluble, dimethylol phenol resins are used either in brominated form, or more commonly, as unmodified resin requiring halogen activation (which is provided by chloroprene in the presence of zinc oxide).

Quinone dioxime cures: Butylrubber is crosslinked by quinone dioxime in the presence of an oxidizing agent. These are used in cable compounds for fast, tight cures, where heat ageing and ozone resistance are of foremost importance. These compounds and scorchy are produce vulcanizates with lower than normal physical strengths.

Halobutyl rubber compounding: For halobutyl rubbers, zinc oxide is used as a vulcanizing agent with low levels of sulphur, stearic acid and sulphenamide accelerators. Bromobutyl shows higher cure reactivity than chlorobutyl. Both BIIR and CIIR will cure with zinc oxide but only BIIR will cure with sulphur alone, no zinc oxide or accelerator being necessary. BIIR can be cured with 0.5 phr sulphur, 1.3 phr MBTS, 3 phr zinc oxide and 1 phr stearic acid; levels of sulphur as low as 0.5 phr will give a rapid and reasonable degree of cure. ZDC can be used in small quantities (0.25-0.75 phr), with zinc oxide cures used in heat resistant applications and to improve compression set.

Peroxide vulcanization is also suitable for BIIR. While IIR degrades rapidly when heated in the presence of organic peroxides, BIIR can be cured with peroxides in combination with a co-agent. Vulcanizates with unusually low compression set, high heat resistance and excellent ozone resistance are produced.

Magnesium oxide and calcium stearate, when used alongwith the above accelerators in halobutyl rubbers, act as retarders. They also have an effect on cure time and state of cure besides increasing the scorch time.

Pre-crosslinked butyl This product is a terpolymer of isobutylene, isoprene and divinylbenzene, the last causing a high degree of pre-crosslinking. The pre-crosslinking increases the green

strength, improves the dimensional stability and reduces the cold flow. The sealant and adhesive industry uses this product which resists sag and flow in preformed tapes for automotive and construction industries and improved ageing and weathering ability.

EPDM EPDM rubbers are amorphous terpolymers. Like other non-crystallizing polymers, mechanical properties of the unfilled EPDM are rather poor, and consequently, reinforcing fillers are added. As extraordinary mechanical properties are not required in applications where EPDM is commonly used, easily processable semi-reinforcing blacks are popular in EPDM compounds. Its low density makes it possible to use high extender oil and filler loadings for economy.

Oil extended EPDM's may be used for low hardness compounds. For high hardness compounds, blends with NR, SBR, high-styrene resins, or phenolic resins are also used.

Generally, the EPDM cure system will contain a thiazole (MBT, MBTS, etc.) in combination with a thiuram and/or a dithiocarbamate. For higher heat resistance, sulphur donor type accelerators may replace part or all of the elemental sulphur, e.g. 3 MBTS, 0.8 TMT, 1 ZDBDC, 0.8 DTDM, and 0.5-0.7 S.

The main chains of the EPDM molecule have no double bond and thus EPDM does not suffer deterioration due to molecular scission even after extended exposure to sunlight and high ozone concentrations. Because of their structure and composition, EPDM polymers are inherently resistant to ozone and weathering. The compounds are generally suitable for severe outdoor or high ozone applications without the need for anti-oxidants, waxes, or other special additives in black or non-black EPDM vulcanizates. Therefore, general purpose diene rubbers such as NR and SBR, which are inferior in those properties, are blended with EPDM.

Although EPDM does not possess the excellent low air permeability of butyl rubber, they are used at fairly low levels in inner tubes to improve low temperature properties, ageing, and processing characteristics.

There are a number of modifications which can be made in EPDM polymers. The different commercial grades currently available vary in polymerization process (solution or suspension), Mooney viscosity, relative molecular mass distribution, ethylene/ propylene ratio, and the third monomer (DCP or ENB) type and amount. Suitable grades may be chosen considering the process to be used, application requirements, and costs.

EPM (ethylene-propylene copolymer) does not have double bonds in the molecule. Hence peroxides are used for curing and the vulcanizates excel in heat resistance. EPDM may be crosslinked with sulphur or peroxide systems with unsaturation in the diene monomer which is pendant or in a side chain. Peroxide cure systems may be necessary if the applications requires resistance to temperatures of 150-175 °C and a very low compression set.

Blending with NR, SBR rubbers is facilitated by the use of high diene EPDM (high unsaturation) rubbers. EPDM commercial grades contain a maximum of 15 double bonds per 1000 carbon atoms in contrast to SBR or BR with 150-250 double bonds per 1000 carbon atoms in the main

chain. Thus, ozone, resistance to heat, and other atmospheric exposure hazards such as U.V. radiation and humidity are excellent.

EPDM may be considered as non-staining, non-migrating anti-ozonant, and is used in 15-30% blend with NK or SBR in white sidewall car tyres. Adhesion to textile of EPDM is somewhat difficult, but can be achieved by using dry bonding agents or incorporating SBR or VP lattices in RFL dips. EPDM compounds are not tacky and suitable tackifiers are necessary for operations involving bonding, knitting, or splicing in manufacturing.

EPDM has excellent electrical insulation properties, i.e. high dielectric strength, low power factors and corona discharge resistance, and radiation resistance. It has good low temperature flexibility and stays flexible above -50°C .

EPDM is resistant to polar solvents such as alcohol, glycol, ketone and phosphate ester, acids, alkalies, salt, and fats. EPDM compounds are used in tank linings where chemical resistance is important. EPDM compounds do not possess resistance to hydrocarbon oils and solvents.

Silicons rubber Low values of tensile strength are usual with unreinforced silicone rubbers. Hence, reinforcement is necessary. Unlike most organic rubbers, silicone rubbers can be either very difficult or impossible to crosslink with sulphur cure systems. The main chemical routes for the vulcanization of silicone elastomers are: (1) elevated temperature cures and (2) Room Temperature Vulcanizing (RTV) mechanisms. In elevated temperature cures, mostly organic peroxides are used. As the organic peroxides are inhibited by most carbon blacks, non-black reinforcing fillers such as precipitated silicas, titanium dioxide, and zinc oxide are used. Room temperature vulcanization is normally used with low-consistency silicone elastomers. Being of low consistency, the material can be easily extruded from a tube or other container and then cured in two-part or one-part systems.

As the uses of silicone elastomers are varied, various grades are available for specific uses, *e.g.* high strength, tough rubber, low compression set, wire and cable, etc. The rubbers suitable for low compression set applications do not also require elevated temperature post cure, following initial vulcanization.

Silicone rubber is the rubber of choice for high temperature service uses. In addition, it has excellent weather and thermal stability, ozone and oxidation resistance, good electrical properties, and extreme low temperature flexibility. The electrical properties of silicone rubber are very good in general but can be varied by compounding ingredients to suit applications such as wire and cable insulation and rubber insulating tapes. Silicone rubber is more permeable to gases than natural rubber and it behaves like a rather open screen.

Chloroprene rubber (CR) Chloroprene rubber grades are differentiated according to viscosity, crystallization tendency, degree of pre-crosslinking and the modifier type used in polymerization. Due to its high steric uniformity, CR vulcanizates from gum compounds or compounds with only inert fillers have higher tensile strength than those from similar SBR or NBR compounds, but not in the same range as that of similar NR based vulcanizates. With CR vulcanizates, tensile specifications have to be met often. CR compounds can be formulated

according to the rules applicable for NR and SBR only in respect of fillers and plasticizers. CR is vulcanized with metal oxides; the formulation may sometimes contain sulphur, or it may be sulphur free. For general applications, a combination of zinc and magnesium oxides is used while lead oxide (litharge or red lead) gives good results where low water absorption is important. The allylic chlorine formed in the 1, 2 addition during polymerization in CR is present to the extent of 1.5 mole % and is the reactive site. The sulphur modified grades require no additional accelerator for vulcanization. In the case of mercaptan and XD-modified grades, ethylene thiourea increases the rate of cure and the modulus but reduces the storage stability of the compound.

The choice of anti-oxidants is also peculiar for CR. Diphenylamine derivatives or *p*-phenylene diamine anti-degradants with ozone protective waxes are used, and quinoline type anti-oxidants are avoided.

High tear resistance can be often obtained with reinforcing silica fillers with the addition of silanes. Other fillers may be used for special applications involving chemical resistance, as for example, (1) for flame resistance, antimony trioxide, zinc borate or aluminium hydroxide, usually with synthetic plasticizers like fire-retardant phosphoric acid esters, chlorinated waxes etc. (2) for resistance to hot water, silicate fillers, talc or chinaclay and (3) for chemical and acid resistance, fine particle talc.

Ester plasticizers reduce the glass transition temperature and improve the low temperature flexibility.

The mercaptan and XD grades are more heat resistant than the sulphur modified grades but while CR is better than NR, it is inferior to EVA, EPDM or IIR in this respect.

With appropriate compounding, the volume resistivity of CR can be raised to 5×10^{13} ohms cm, with a dielectric constant of about 6, a dielectric loss factor of about 0.045, and a dielectric strength of about 25 KV/mm. CR is thus suitable for cable sheathing compounds and for low (up to 750 V) voltage insulation. In contrast, loadings of carbon blacks of high structure (conductive blacks) lead to conductive or antistatic vulcanizates with volume resistivity 10²-10¹⁰ ohm cm.

To avoid sticking of CR compounds to the mill in processing, addition of stearic acid (0.5 to 1.0 phr), paraffin wax, low molecular weight polyethylene or polybutadiene as processing aids is often necessary. The temperature of compounds without accelerators should not be allowed to exceed 130 °C in processing because CR shows a tendency to cyclize at high temperatures. The effect of heat is cumulative and may result in progressive reduction of the processing safety. Therefore, mills at low friction ratios (1:1.1 or 1:1.2) are needed to minimize heat build up.

CR has a combination of several technically essential properties such as good mechanical properties, heat resistance, ozone and weathering resistance, flame resistance and adequate electrical properties for many applications, which are not obtained with other kinds of tonnage rubbers at a comparable price. Thus it has a broad application spectrum.

Reclaim: Apart from its role as a cheapening extender, reclaim in many cases aids processing considerably by reducing nerve. It is also a useful ingredient in stocks required for bonding to metal, as it confers improved adhesion. Batches containing reclaim are mixed more easily and rapidly. Where high physical properties are not necessary, it is possible to use large quantities of reclaim rubber. One balances performance, cost, and processing before making use of reclaim. It is better value for money than cheap fillers like clay and it assists processing. In higher proportions it can adversely affect physical properties like resilience, fatigue, and abrasion resistance.

Manufacture of Rubber Products

PNEUMATIC TYRES

A tyre is an annular toroidal-shaped inflatable envelope, made of rubber, which is reinforced with cord, enclosing coiled wire bead rings. It is fitted to a metallic rim which is secured to the vehicle.

A pneumatic tyre performs the following principal functions:

- (a) It supports the weight of the vehicle. It transmits the forces on the vehicle to the ground, e.g.
- (b) It helps to convert the engine torque to movement of the vehicle.
- (c) It gives a more comfortable ride to the passengers or cargo in the vehicle by:
 - Acting as an additional spring in the suspension system.
 - Elastic deformation over undulations on the road.
- (d) It permits cornering on the road at relatively high speeds by its capacity to generate higher cornering forces than would have been possible with a solid tyre.

Classification

Tyres may be classified in the following ways:

Tyre and Rim Notations. The tyre size which is prominently displayed on the sidewall indicates the approximate dimensions of the tyre. Many systems of tyre sizing are in vogue and the two most commonly used systems are explained below:

- Size "9.00-20" indicates that the tyre has a section width of approximately 9" and is fitted on a rim of 20" nominal bead diameter.
- For radial ply tyres, size 145/70R12 denotes a tyre with section width 145 mm, radial ply and nominal rim diameter code 12, and an aspect ratio of 70.

The ply rating of a tyre is also displayed on the sidewall, and indicates its load carrying capacity. It should be noted that it does not necessarily represent the number of casing plies. The actual

load carrying capacity may be obtained by reference to published standards. In India, the Bureau of Indian Standards (BIS) has published this data. The ratio of tyre section height to width is called 'aspect ratio'.

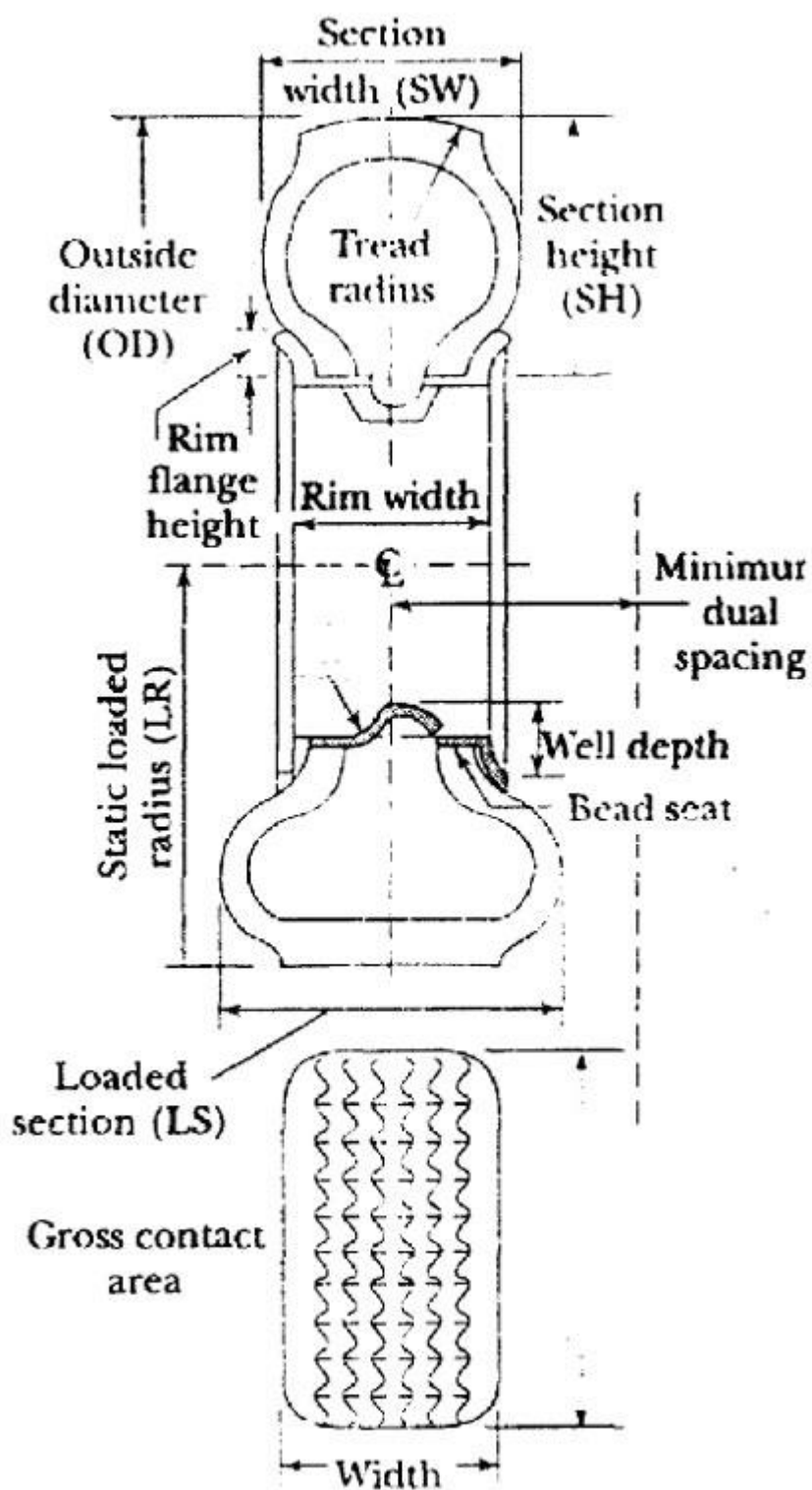

Construction Tyres may be classified by the type of casing construction used and the principal physical difference between the casing constructions lies in the angles of the casing and breaker cords. The two basic casing constructions are as follows:

- *Cross ply* The casing angle and the breaker angles are generally equal and in the region of 40° , with cords in alternate plies running in opposite directions.
- *Radial ply* All the cords in the casing run in a radial direction and breaker cords are at a very low angle, i.e. almost circumferential.

All aspects remaining the same, the mileage potential of radials is the best.

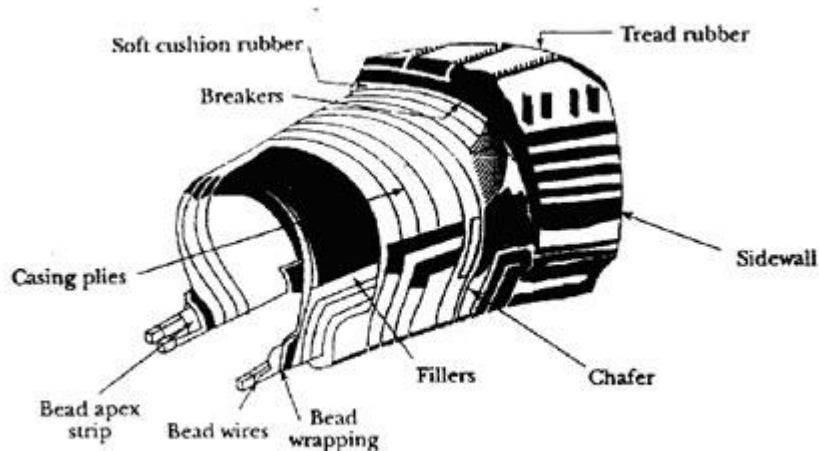

Tread Pattern Design Tyres used on hard dry roads do not need patterned treads. However, on wet roads, the water acts as a lubricant between the tread rubber and the road, thus, drastically reducing the friction and hence grip of the tyre on the road. The pattern on treads helps to remove much of the water between the tyre and the road, thus improving the grip.

Tread patterns are of two basic types which are listed below. Various combinations of these types of patterns are in use which aim at providing specific properties for specific service uses and also to improve visual impact.

Fig. 3 shows in simplest terms the fundamentals of tread pattern design. The basic patterns have the following features:

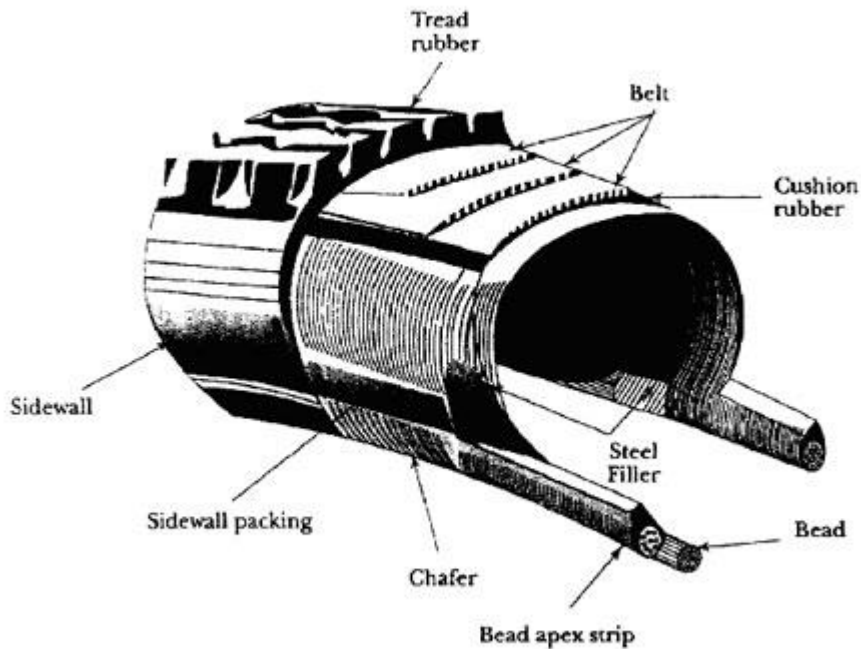

- *Circumferential or ribbed pattern* Its features are: Good lateral grip; even wear; and silent running.
- *Transverse cross-ribbed or lugged patterns* Good fore- and aft grip; tendency to irregular wear and reduced grip; and noise on running are some of its properties. From these two basic patterns, others can be derived by addition and distortion. The simplest of these is produced by simple addition or combination of the basic two.
- *Square studs* They have the features of-good grip in both directions; tendency to irregular wear; noise on running; and instability on cornering due to flexibility of units.
- *Ribs with side studs* This is a simple commercial pattern. It is used for industrial tyres and for front wheel grader tyres. Its properties are: good resistance to wear; good steering due to longitudinal ribs; and side studs ensure that rotation and steering are maintained on soft surfaces.
- *Diamonds* This was a well-known pattern for earth mover and other tyres. Properties were very similar to those of square studs, but slightly improved-good grip in all directions; somewhat reduced tendency to irregular wear; and reduced noise.
- *Improved ribs and side studs* The basic properties are similar to those quoted under ribs with side studs for general on-and-off the road use.
- *Symmetrical transverse* In this case, the simple transverse bar becomes a chevron, balanced about the centre line of the pattern. This type of pattern is widely used. The properties are: maximum grip and drive on rough and loose surfaces; tending to irregular wear if run on smoother roads; and no sideways reaction on drive or braking.
- *Asymmetrical transverse* There have been a whole range of such designs, based on helical gear wheel designs. The properties can be altered by doing subtle changes to groove shape, tread radius, and shoulder contour. The basic types of highway truck tyre designs are rib, lug, and semi-lug.

Rib Type Treads Tyres with rib type tread are "all position" tyres. They can be used on all wheel positions at legal highway speeds. These tyres are always recommended for steering wheel use on longhaul, high-speed service. The circumferential groove design provides maximum steering capability and good skid resistance.

Lug Type Treads Lug type tyres are designed for drive wheel service. The design provides greater traction in high torque application.

Semi-lug Treads Semi-lug type tyres are designed for drive wheel service and are suitable for many off-the-road operations. These tread designs provide maximum resistance to wear and greater traction in high torque service. These designs are also suitable for steering wheel application.

Some examples of patterns for specific applications are listed below.

- Tractors used on wet fields have drive axle tyres which have deep transverse bars which bite into the soil and thus provide the required traction. The bars are placed at angle, so that the mud can slip off the tyre and the pattern is always reasonably clean when it makes contact with the wet surface.
- Tyres used in deserts where the sandy surface is very soft and extremely deep have very shallow circumferential patterns. Deep transverse patterns would dig into the sand and get embedded in it. An absolutely bald pattern would have been the best in these circumstances so that the load on the sand is distributed over a larger area thus reducing the chances of the tyre getting embedded in the sand. However, as these tyres are sometimes used on hard roads which may be wet, shallow circumferential patterns are generally used.

Tubed and Tubeless Tyres Air at high pressure is required to be enclosed between the tyre and the rim. In general, this is achieved by using an air-tight elastic tube made of rubber compound which is placed inside the tyre and rim assembly. These tyres are referred to as tubed tyres or conventional tyres.

In some cases, it is possible to achieve air seal between the tyre and the rim without the use of tubes. This is done by having a thick layer of rubber inside the tyre which acts as an air envelope. These tyres are known as tubeless tyres. They are used on special rims.

Components

The three main parts of a tyre are-casing, tread, and bead.

Casing The casing, which is made of layers of textile cord fabric surrounded by rubber compounds, provides the strength of the tyre. The following components make up a typical casing.

Plies These are layers of textile cord fabric, coated with rubber compound which are cut to the required dimensions and bias angle. They are locked around the bead wire coils. The textile may be cotton, rayon, or nylon. Steel, glass fibre, and polyester are also used.

Inner liner This is a layer of rubber compound fitted inside the tyre to protect the plies. In the case of tubeless tyres, a thick inner liner is used (see item d), and often a special formulation for lower air permeability is chosen.

Insulations These are layers of rubber compound fitted between or over the plies to provide extra reinforcement or cushion to the casing in critical regions.

Breakers These are relatively narrow bands of cord fabric coated with rubber and are fitted where necessary on top of the plies. They absorb high instantaneous shock loads and distribute them evenly over the casing. They may also be used to provide additional stiffness to the tread.

Chafers These are layers of textile fabric coated with rubber which are fitted over the casing in the bead region. They protect the casing from damage due to chafing with the rim or during mounting or dismounting from the rim.

Tread It is a relatively thick layer of rubber which is fitted over the casing/breaker assembly and protects the casing from external physical and environmental damage.

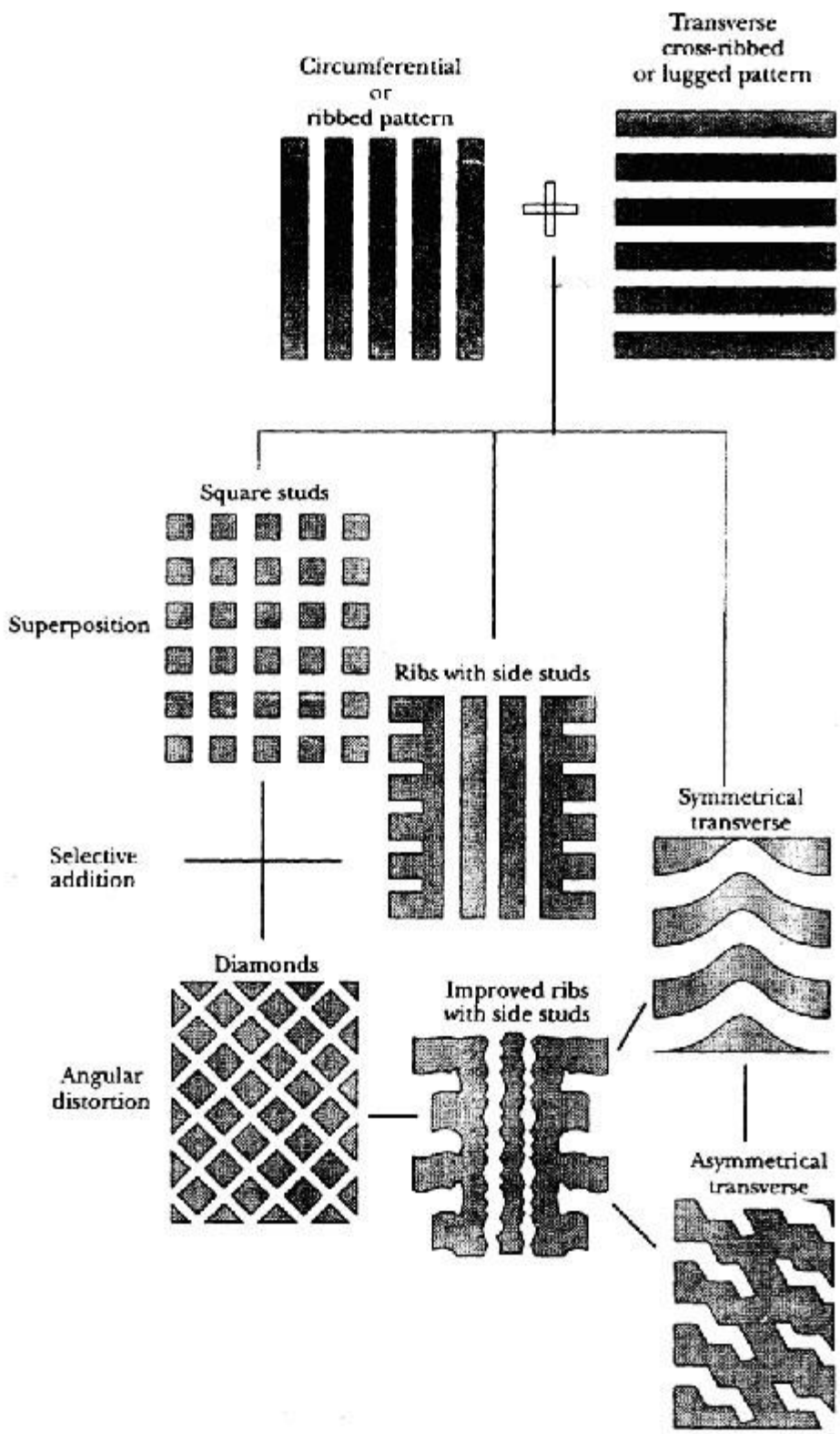

The top portion of the tread which comes in contact with the road is patterned as required for the service conditions. The sidewall region may also have patterns, generally for visual impact. The size, type, ply rating and manufacturer's name are generally displayed on the sidewall. In the case of bicycle tyres, a number of combinations are used, for example, two tone colours such as white and brown, ribbon or stripes on one or both sides, open sidewall tyre which has practically no rubber on its sidewall, or fluorescent line tyre where a fluorescent paint or strip is used.

Beads Beads consist of one or more coils of rubberized wires fitted generally with wrappers, fillers, and apices. The bead being relatively inextensible, locks the tyre to the rim. A typical bead is made up of the following components:

- *Bead coil* These may be of one wire or more and is coated with rubber if more than one wire is used. The wires are generally made from copper-coated steel.
- *Wrapper* This layer of textile fabric, coated with compound, which is wrapped around the bead coils, keeps the layers of wires in position and provides good adhesion between the bead coil and the surrounding casing or fillers.
- *Apex* An apex is fitted over the wrapper and is generally triangular in shape and made of rubber compound. They help in improving the bead shape and bulk and avoid the formation of air pockets at the turn-up region.
- *Filler* This is made of textile fabric coated with rubber and fitted over the wrapped bead and apex assembly.

Preparation of the Components Rubberized fabrics from the calender are cut to strips at an angle in a "bias-cutter". These strips are joined together end-wise so that a continuous strip (cut ply) is formed having the cords at an angle to its length. The width of the strip is arranged to suit the size of the tyre to be made. Two such strips are then plied together so that the cords form a criss-cross or trellis pattern. Insulation rubber is applied on the ply as specified.

Beads are produced by passing a group of wires through a T-head extruder so that they become embedded in a rubber tape. Layers of this type are wound onto a drum until the required thickness is built up. The whole is wrapped helically in a strip of rubber-covered fabric. After applying apex compound strip, a second rubberized strip, called the "filler" is folded around the bead.

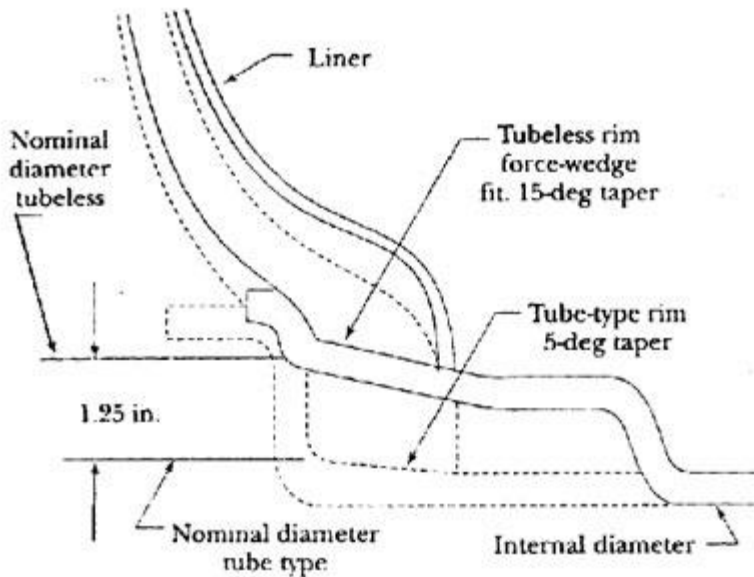
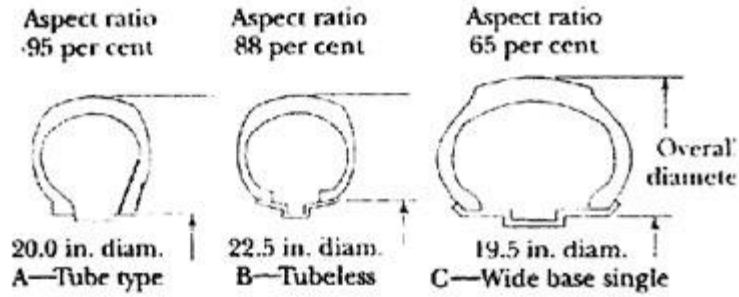

The sidewalls and tread are frequently made of different compounds, which are extruded either separately, or as a combination secured by arranging two extruders in tandem.

Reclaimed Rubber

INTRODUCTION

Reclaimed rubber is the product resulting when waste vulcanised scrap rubber is treated to produce a plastic material which can be easily processed, compounded and vulcanised with or without the addition of either natural or synthetic rubbers. It is recognised that the vulcanisation process is not truly reversible; however, an accepted definition for devulcanisation is that it is a change in vulcanised rubber which results in a decreased resistance to deformation at ordinary temperatures.

Reclaimed rubber is manufactured by suitable treatment to old and worn out tyres, tubes and other used rubber articles with certain chemical agents. A substantial devulcanisation or

regeneration is effected to the rubber compound in this process whereby its original plasticity is regained. In short it may be stated that reclaiming is essentially a depolymerisation process where the combined sulphur is not removed. The reclaimed rubber is used in the manufacture of rubber goods, with or without admixture of natural or synthetic rubber.

Recycled rubber can be more generally described as any sort of rubber waste that has been converted into an economically useful form such as reclaimed rubber, ground rubber, reprocessed synthetic rubber, and die-cut punched parts.

One method of recycling some scrap rubber is to grind it as fine as possible and work it into new rubber as an elastomeric filler. This was the first method of reclaiming and is suitable only for compounding carriage springs, which were fairly large barrel-shaped molded articles but not suitable for footwear products.

In order to make a high-quality reclaim, the fibre must be removed from the rubber scrap by soaking the rubber in water, and then taking a small knife and starting the rubber from the cloth and stripping it off. But this was not an effective way to produce large quantities of products.

TYPES OF RECLAIM

A variety of grades of reclaimed rubber is offered today, but mention is made here of only the important ones.

Whole Tyre Reclaim

Whole tyre reclaim is the one produced in the largest quantity. First-quality reclaim made from whole tyres contains about 45% rubber hydrocarbon by weight. The remaining 55% consists of valuable carbon black, a little mineral filler, and softeners, all of which are substantially unchanged by the reclaim manufacturing operation, and may be considered to function as virgin materials. The manufacturing process of tyre from reclaim rubber is shown in Fig. 1.

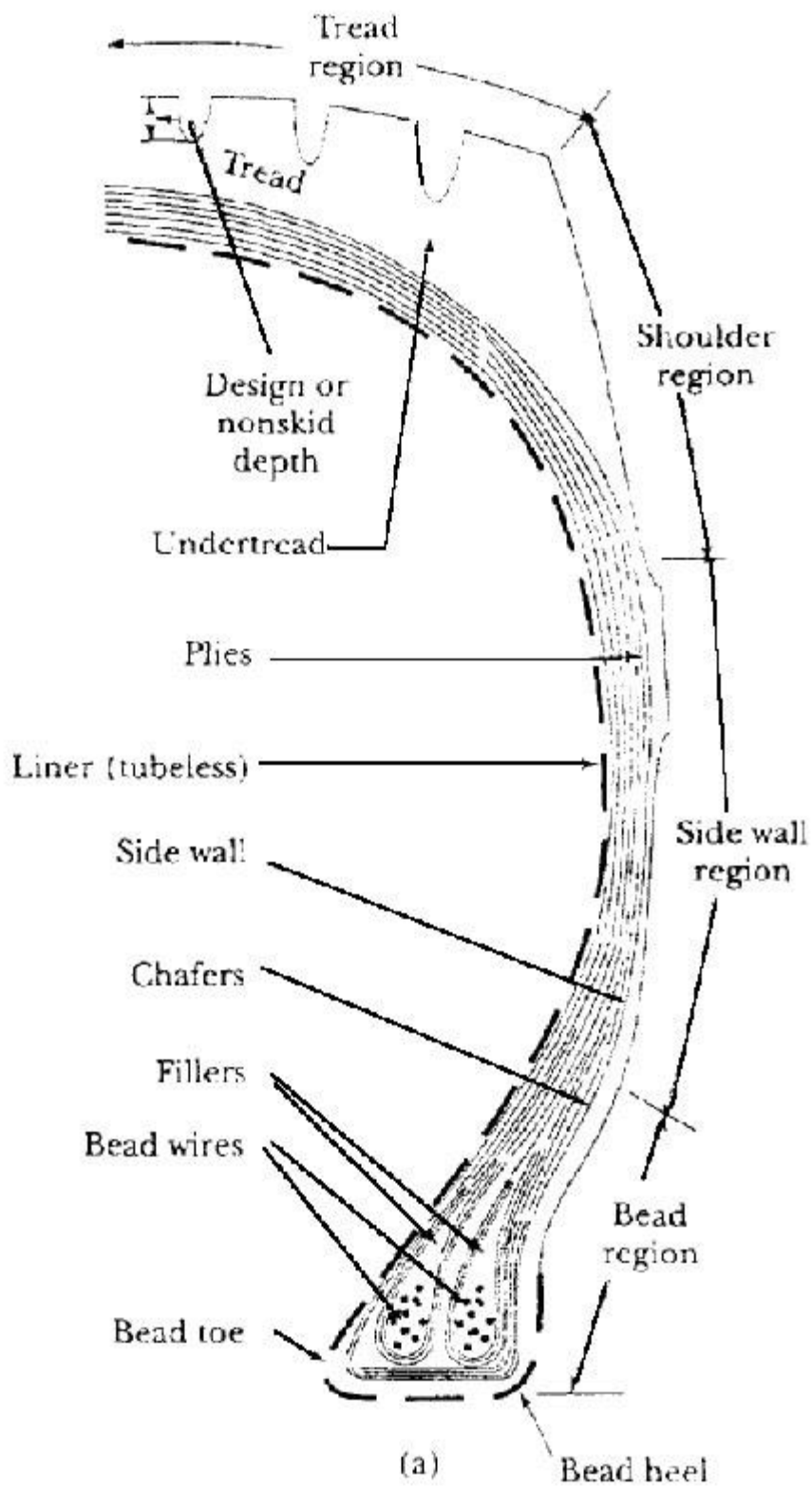

Minimum Staining Reclaim

Minimum staining reclaim can replace the conventional whole tyre material when occasion demands. As implied, it has a much lower tendency to stain, by either migration or contact, than conventional reclaim. The reduction in staining characteristics is achieved by the use of activated-carbon non-staining oils and by selecting tyres containing a higher proportion of natural to synthetic rubber.

Drab and Coloured Reclaims

As the names imply, drab and coloured reclaims are made from non-black scrap. The digester process is usually employed and, when fabric is present, a small addition of caustic is made in order to destroy it. The period of heat treatment is usually several hours at 195°C.

Butyl Reclaim

Whereas reclaimed rubbers have been successfully produced from scrap CR, NBR, SI, and other speciality rubbers, the only one of substantial commercial importance is butyl reclaim. The starting material for this is butyl inner tubes. A modified digester process is adopted, every precaution being taken to avoid contamination by NR or SBR, because of their adverse effect on the curing characteristics of the butyl. Extensive control tests are necessary to ensure that the curing properties are satisfactory. The nerve of butyl reclaim is much reduced compared with that of the original polymer. Because of this, compounds containing butyl reclaim will mix, calender, and extrude faster and more smoothly than similar compounds based on virgin rubber.

EVOLUTION OF RECLAIMING PROCESSES

It had been common knowledge for many years that acid has a degrading effect on fabric and that rubber is resistant to acid. In the acid process, the ground scrap was boiled for several hours in a fairly strong solution of either sulphuric or muriatic acid to destroy the fabric; the rubber was washed and then devulcanised with high-pressure steam in the pan process. It was a two-step operation.

Although the acid process was used quite successfully for a period of time, there were problems with the method. If the acid was not thoroughly washed, it could cause poor ageing characteristics. More important, there were coming on the market many types of higher-sulphur scraps, such as bicycle-tyre scrap, that could not be processed by the acid method. If the high quantities of free sulphur in such types of rubber scraps are not removed, they tend to cause further vulcanisation during the open steam heater process rather than devulcanisation. Something better was needed.

A breakthrough came with the invention that came to be known as the *alkali digester process*. The ground rubber, fibre, and a dilute solution of caustic soda were cooked at high pressure for about 20 hours. This system caused the defibring, desulphuring, and devulcanisation of the rubber scrap *all in one step*. This technique could be used to reclaim any type of rubber scrap available at that time. Later on, an improved method which involved steam-jacketing the vessel and agitation of the mass is developed. This is the cooking method used by most reclaimers.

In the devulcanisation of rubber two other important developments involved the introduction of new machines to greatly improve the quality of reclaimed rubber. One development was the *refiner*, which is a special type of mill used to produce a much more smooth and homogeneous product than would otherwise be possible. The other was the *strainer*, which is used to remove foreign matter from the rubber. With the exception of invention of the reclaimator.

RECLAIMING PROCESSES

Scrap-rubber Preparation

The first stage of any reclaiming process is size reduction of the scrap. This is most generally accomplished using corrugated two-roll cracker mills. Other types of equipment have been employed such as a rotating cutter to obtain a rip, tear, or shear action, while others have rotating-knife slitter actions. The capital cost for these types of equipment is less than for a standard two-roll cracker installation; however, in most cases they have not been proven to be heavy-duty enough to withstand 24-hour operation.

The tyre bead wire is either cut from the carcass before grinding or manually removed after the first pass through the cracker. At many points in the system, the ground rubber is passed over magnetic separation equipment to remove remaining bead wire and steel belt wire. Gyrotory classifier screens return the oversize rubber particles to the cracker for further size reduction. There may be more than one stage of grinding before the desired size of approximately 3/8 inch is obtained. At this point, the coarse-ground rubber could be conveyed to the digester or processed further for one of the other devulcanisation methods.

The fibre from the coarse-ground tyres is removed by some sort of fluidised-bed, specific-gravity table. The action of controlled streams of air moving through a bed of ground rubber on an inclined gyrating table of special design causes the fibre to separate from the clean rubber. The size of the rubber particles may now be further reduced to perhaps 20 or 30 mesh by fine grinding. Fine-corrugated, high-friction mills are employed in this operation.

Reclaimed Rubber

By the application of heat and chemical agents to ground vulcanised waste rubber, a substantial regeneration of the rubber compound to its original plastic state is effected, yielding a product known as 'reclaim' or reclaimed rubber, capable of being processed, compounded, and revulcanised. The process is essentially one of depolymerisation. Reclaimed rubber has become widely accepted as a raw material which possesses processing and economic characteristics that are of great value in the compounding of natural and synthetic rubber stocks.

There are four principal reclaiming processes in use today, of which the digester and reclaimator processes are important.

The raw material for reclaiming is scrap rubber in a wide variety of forms, but tyres, as is to be expected, form the major quantity.

The first stage, in all processes, are the cracking and grinding of the scrap rubber to reduce it to a crumb passing through a 20 to 30 mesh screen.

Digester Process

At one time, most reclaim was made using the digester process. A digester is essentially a steam-jacketed, agitator-equipped autoclave, mounted either horizontally or vertically. This is a wet process in which the coarsely ground scrap is submerged in a solution of water and reclaiming agents. These agents may include many types of light and/or heavy oils, naval stores, pine tar and coal tar pitches, and chemical peptisers.

Until the advent of synthetic rubber, the digesting solution also included caustic soda to remove free sulphur and to act as a defibring agent. In fact, the process was generally referred to as the *alkali digester method*.

The ground waste is loaded into a digester along with water, reclaiming oils, and other additives, such as activated black (for minimum staining grades). The digester is a cylindrical jacketed pressure vessel fitted with a horizontal agitator, and steam can be supplied to both interior and jacket, thus enabling a uniform temperature to be maintained throughout the mass. The contents of the digester are then heated to about 190°C and maintained at this temperature for some 4-10 hours with continuous agitation. The digester is then 'blown down', and the contents deposited on to a conveyor. Any necessary adjustments to the specific gravity and plasticity by addition of plasticiser, carbon black, or fillers are carried out in a ribbon blender, and the stock is then automatically conveyed to extruders for straining, refining, and leafing on to a drum from which it is removed in slabs.

Reclaimator Process

The reclaimator process is the only commercially successful continuous technique for devulcanising tire scrap; all the others are batch processes. Tyres are ground, the metal and fibre are mechanically separated, then the rubber is further ground to a fine particle size. This fine-ground rubber and the various reclaiming agents are all metered into a blending system and conveyed to the reclaimator.

The reclaimator is a special type of screw-extrusion machine. It is jacketed to provide for several zones of controlled temperature using either hot oil or cooling water; in addition, the clearances between the screw and the chamber wall are close and adjustable. The object is to subject the rubber to a controlled amount of high heat and pressure in a continuously moving environment. The residence time of the rubber in the machine is less than 5 minutes. During this period, the rubber undergoes devulcanisation. After the softened rubber is discharged from the head of the machine, it is cooled and further processed in refining mills just as is done in other reclaiming methods.

It can be shown that ground vulcanised rubber heated in a temperature range of 120-200°C undergoes a rapid initial increase in plasticity, and, on continued heating, passes through an

inversion point and rehardens unit, after prolonged heating, a further but slower increase in plasticity is attained. It follows, therefore, that three points of equal plasticity occur in this cycle.

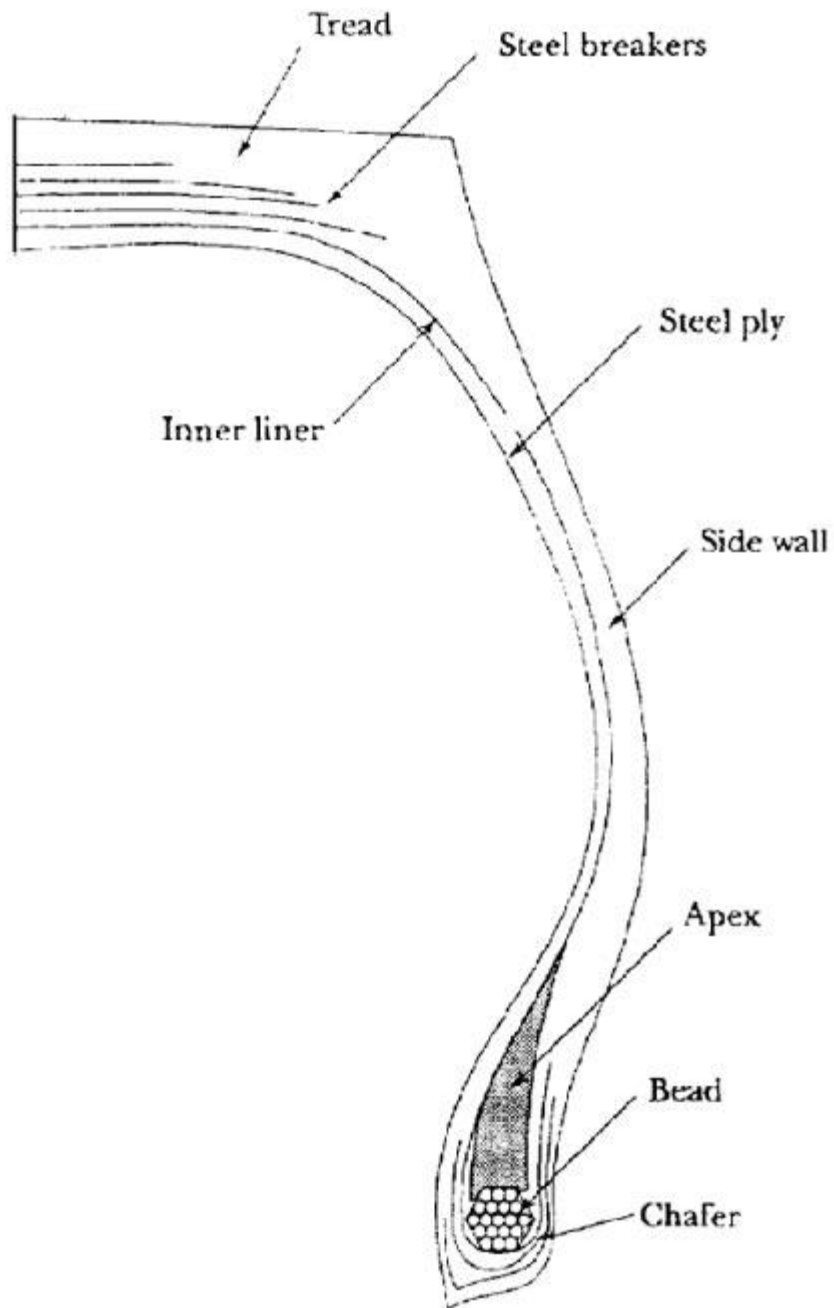

Although this behaviour is characteristic for certain vulcanised rubbers, the resultant plasticity-time relationship will vary with the type of rubber, reclaiming agents, and physical conditions used. Synthetic rubbers behave in a similar manner, but the rehardening process tends to

predominate, so the initial increase in plasticity is less marked and can only be achieved under special conditions.

Whereas some earlier processes completed the cycle mentioned above, the reclaimator process depends on arresting the reaction at the point where the initial rapid increase in plasticity is achieved in the presence of plasticisers, oxygen, and catalytic materials. The rapid heating of the rubber while it is being worked mechanically gives the desired plasticity in a matter of 3-6 minutes. The total cycle time is only 30 minutes, and the process is entirely dry.

The reclaimator machine, from which the process takes its name, is of the screw extrusion type with a hopper at one end into which the crumb previously mixed with oil and chemicals is automatically fed at a predetermined rate. It generates its own heat for depolymerisation by mechanically working the finely divided rubber crumb under pressure, and then discharges it as reclaimed rubber. Temperatures in the machine are controlled by alternating oil and water jackets.

The raw material for this process is whole tyres, and, in the preparation of the crumb, fabric is removed mechanically by a series of operations in which fractionating and sizing screens, harmer mills and reel beaters, air flotation, and gravity tables are used. The reclaimed rubber is compounded as necessary and refined and sheeted using conventional machines. The full sequence of the above operations is shown in the flow charts.

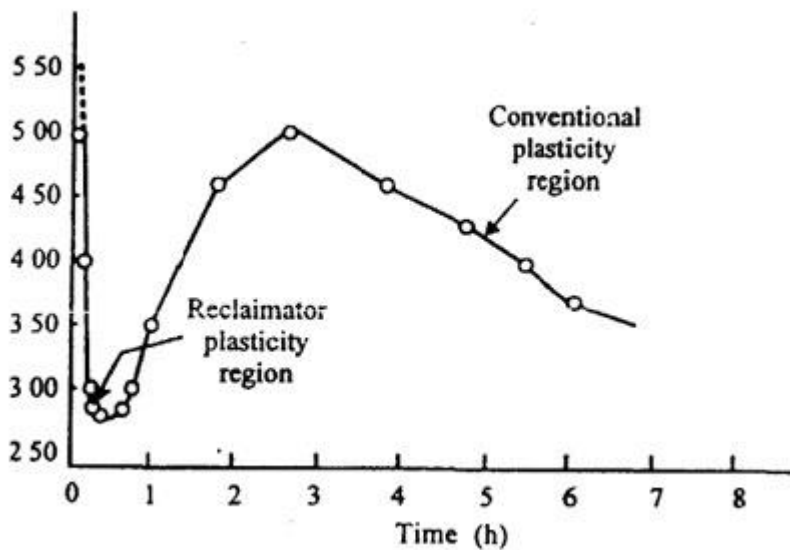
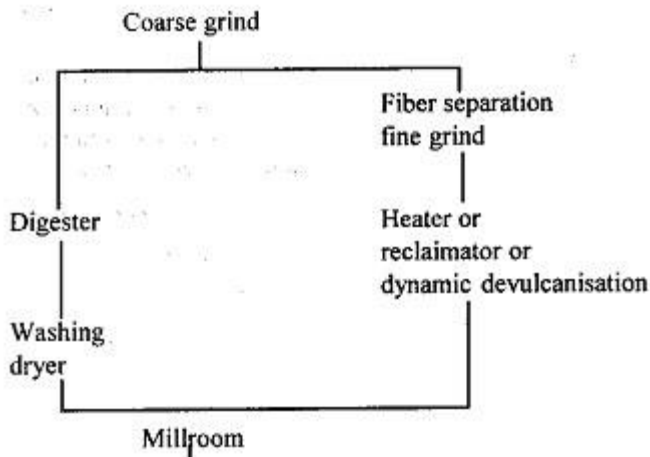

Pan Process

This is the simplest of all the reclaiming processes. A "heater" is a large, single-shell horizontal pressure vessel or autoclave. The ground rubber is mixed with reclaiming agents in an open ribbon mixer, then placed into containers rolled into the vessel. The main consideration is to allow an even penetration of heat in the mass of rubber. To achieve this uniform steam penetration, shallow pans or boats equipped with hollow metal pipes or inverted "V" sections are used as the stock containers. Live, steam at pressures of 100-250 psi with cycle times of 5 to 12 hours are typical.

The raw material, fabric free, is cracked on the same type of equipment as for whole tyre. The ground waste intimately mixed with the required oils is loaded into steam vulcanisers and subjected to steam heating at pressure of the order of 10 kg/cm². This is followed by straining

and refining in the conventional manner. Not only NR and SBR scraps but also IIR, CR, and NBR compounds are reclaimed by this method.

Engelke Process

This process is extremely simple as it requires no wetting of the stock or elimination of the fibre. Vulcanised scrap rubber containing fabric is subjected to very high temperatures for short periods of time, 10-20 minutes and upwards, in small autoclaves. Any fibre is completely carbonised in situ throughout the mass. The cracked stock, when necessary, can be premixed with plasticising oils and peptisers. The reclaim is strained and refined in the usual manner.

Tests Applied to Reclaimed Rubber

Chemical

Acetone extract
Carbon black content
Ash content and composition
Total polymer content and Composition
Chloroform extract
Alcoholic potash extract
Cellulose content
Acidity or alkalinity

Physical

Visual inspection for smoothness and freedom from metal contamination
Plasticity
Specific gravity
Rate of vulcanisation
Physical tests on the vulcanised reclaim (i.e., tensile, modulus, elongation, tear strength, and hardness)
Staining characteristics
Colour and odour
Extrusion rate
Filler incorporation characteristics

Testing and Evaluations of Reclaimed Rubber

The testing and evaluation of reclaimed rubber includes both chemical and physical testing. Although the list of tests given in Table 1 is very comprehensive, the decision as to which tests must be applied to a particular reclaimed will depend upon the end product and the specification agreed between the consumer and manufacturer. In general, the test methods are those laid down by the BS1 for the testing of vulcanised rubber.

DYNAMIC DEVULCANISATION

The digester process has been used for decades, and millions of tons of excellent-quality reclaim have been produced. However, it became apparent that the many problems associated with this

process doomed it to extinction. The digesting solution had to be disposed of after each cook; this caused water pollution. The rubber had to be washed after the cook; this caused a loss of some of the finer particles of rubber as well as produced more water pollution. The wet rubber crumb had to be dried with large amounts of warm air; this caused air pollution. The drying step also required large amounts of energy. The cycle times were long; the overhead costs were high. A better process was needed.

The heater or pan process solved many of the problems of the digester process but had its own problems. Although it is a satisfactory method for cooking some types of scrap rubber, it is highly unsatisfactory for whole-tyre reclaim; the cooked mass is much too non-uniform.

The dynamic devulcaniser is essentially a marriage of the best features of the digester and heater processes. It is a large horizontal autoclave with a shaft down its axis on which are mounted a series of paddles arranged so when the shaft is rotated, the rubber inside receives the maximum amount of agitation. The mechanism must be built much more sturdily than the agitator on a digester because the rubber is to be cooked dry. The scrap rubber is agitated throughout the cook cycle so as to achieve total uniformity within each batch. The rubber is cooked with live steam and needs no washing or drying; there is no water pollution. The steam blowdown must be scrubbed or treated in some other way to avoid air pollution, but this is a much smaller problem than with the digester process. Since there is no loss of rubber in a wash cycle, the scrap tyres can be ground much finer prior to the cook. This fine-ground rubber allows a much more uniform-distribution of the reactive chemicals used in the process and results in a higher-quality product.

The dynamic devulcaniser enables a higher-quality product and also a more economical one. The finer particles of rubber and its continuous agitation allows higher steam pressures and shorter cycles. The greater uniformity of the cooked stock allows higher production rates in the millroom. Both of these factors increase productivity and reduce costs in a very capital-intensive industry- necessary if reclaim is to compete against synthetic rubber in the market.

Millroom Operations

The rubber that has been softened by one of the methods described above is then conveyed to the millroom for the final stage of the reclaiming process. The stock is generally first mixed with weighed amounts of pigments, carbon black, or other ingredients in a blender. Next, an extended barrel mixer strainer may be used to warm and plasticate the stock. It is then fed to a high-friction breaker mill and on to the strainer where tramp metal and other foreign particles are removed. The final milling step is the finishing refiner. A high friction ratio for the refiner mill is achieved with different-size rolls turning at considerably different speeds. The rolls are set quite tightly to obtain a thin sheet of rubber. The object is a product that is smooth, uniform, and free of grain or lumps.

In the past, the finished sheet from the refiner was pulled to a windup drum and allowed to build up to a thickness of perhaps an inch before being cut off by hand with a small knife. The resulting rubber slab was dusted and stacked. Today most reclaim manufacturers use balers to package their product.

THE ADVANTAGES OF USING RECLAIMED RUBBER

The primary, but not exclusive, advantage of using reclaimed rubber in the manufacture of tyres and other rubber goods is one of cost. There are, of course, the direct cost savings resulting from the lower cost of the reclaimed product as compared to natural rubber and virgin synthetic rubbers, but there are equally important indirect cost benefits resulting from the proper use of reclaim.

Special Strengths Through Reclaiming

Whole-tyre reclaim is extremely uniform due to the extensive blending that occurs at every step of the manufacturing process. What is produced is best considered as a unique new raw material rather than some sort of modified SBR/natural blend. Just like any other ingredient chosen by the compounder to be incorporated into a formula, the raw material-reclaimed rubber-has its specific purposes. The purpose of reducing formula compound cost is certainly a legitimate one; however, there are other reasons to include reclaim in a formula that will result in processing advantages and indirect, but real savings.

When the vulcanised tire rubber is reclaimed, it is softened through a reduction by scission of the molecular weight of the cross-linked elastomeric chains. That is, carbon-carbon bonds in the synthetic and natural-rubber polymers are broken, not the sulphur cross-links that are formed when the tyre is vulcanised. The result is a system of cross-linked fragments that is much more "three-dimensional" in nature than the original polymers.

The three-dimensional character of the rubber fragments causes the reclaim to have properties different from the original tyre compound. The shorter length of the polymer chains that make up the fragments give a lower tensile strength than the original compound when the reclaim is revulcanised. However, the three-dimensional nature of the fragmented elastomers in reclaim also produces some very desirable properties. The most important of these is the dimensional stability and reduced nerve imparted to compounds that include reclaim, improving the rate and the gauge stability of calendered and extruded stocks. The improved calendering production rate and lower reject rate result in significant cost savings that should be considered in the calculation of formula costs.

Rubber Natural

Natural rubber (NR) (*cis*-1,4-polyisoprene) occurs in over 200 species of plants. The *Hevea brasiliensis* tree accounts for over 99% of the world's natural rubber production, which, in 1986, amounted to over 4×10^6 t.

The earliest written references to natural rubber were made by Spaniards following the voyages of Columbus in the late 15th century. Antonio de Herrera Tordesillas (1601) described a game at the court of Aztec emperor Montezuma II that used a rubber ball. From the 1600s onward, samples of rubber were brought back to Europe from the New World as a curiosity. The first serious investigations of rubber were made in the mid-1700s by Charles de la Condamine and Francois Fresneau. The former became interested during his travels in South America in what he

referred to as caoutchouc, a word derived from the local Indian word meaning weeping wood. He described various uses that the Indians made of coagulated latex such as boots, liquid containers, and waterproofing cloth. The French, from that time on, used the word to describe rubber. In 1770, the word rubber was coined by Joseph Priestley when he observed that gum from the *Hevea* tree could be used to rub out pencil marks.

Fresneau was the first to describe the caoutchouc tree that he found in Guiana. It was named *Hevea guianensis* 25 years later by the French botanist Aublet. Fresneau described the collection of latex and articles made by drying and preserving the latex in the presence of smoke.

The reports of Fresneau and de la Condamine generated interest in rubber, which led to the discovery of solvents for crude rubber. The ability to dissolve rubber was the first step in the manufacture of articles. The first useful solvents included turpentine, purified ether, and rectified petroleum.

The next significant event in the development of the rubber industry was the invention of the masticator in 1820 by Thomas Hancock. The masticator softened rubber, which facilitated dissolution. Solutions of rubber were used in 1823 to make waterproof garments, which, however, were not satisfactory as the rubber softened in sunlight and became brittle in the cold. In 1839, Charles Goodyear discovered that rubber and sulfur combined in the presence of heat and white lead yielded a new substance with improved physical properties. This process became known as vulcanization. The white lead acted as an accelerator. Goodyear did not apply for patents on his process until 1843. In the meantime, Thomas Hancock also discovered vulcanization and obtained the British rights to the process. Although Hancock was able to register his patent first, Goodyear is generally recognized as the discoverer of vulcanization (qv).

The year 1876 signaled the beginning of the plantation era, and 70,000 rubber seeds gathered from the Amazon basin were planted in Kew Gardens, London; ca 2800 of the seeds germinated. In 1877, ca 1920 rubber plants were shipped to Ceylon (Sri Lanka) and planted. A few plants were sent from Ceylon to Malaya and from there seeds and plants were sent to Singapore, India, and Java. In the late 1880s, ca 1000 trees were growing in Malaya. In 1888, the first practical pneumatic tire was developed, which eventually led to an unprecedented demand for rubber. At about the same time, it was demonstrated that rubber trees could be grown in cleared areas, in regular order, and could be tapped at intervals of a few days, thus leading to an efficient and economical recovery of the latex.

Agriculture

Producing *Hevea* trees grow to heights of 15-20 m and require a well-distributed annual rainfall of at least 180-250 cm. They grow well where precipitation is 500 or even 750 cm, but excessive rainfall interferes with tapping. The *Hevea* tree thrives at altitudes up to 300 m and is adaptable to most soils, provided drainage is adequate. It is well documented that there is an inverse correlation between yield per tree and planting density. It has also been proved that yield per hectare (10,000 m²) increases with planting density up to a point. The current practice on rubber estates calls for planting 400-500 trees/ha. Small holders, whose average holding in Malaysia is 2.5 ha, may plant as many as 740 trees/ha in order to maximize family income over the short

term. The average yields in Malaysia improved from 552 kg/ha in 1965 to 992 kg/ha in 1980. This increase represents an average of smallholders and estates. Well-run estates in both Malaysia and Indonesia increased their yields to over 1500 kg/ha during the same period. Yields are expected to increase significantly by the end of the century as new, higher yielding trees come into tap and agricultural techniques improve. Experimental yields of 3000-4000 kg/ha have been achieved, and theoretical considerations indicate yields of 9000 kg/ha may be possible.

Rubber trees can be propagated by sexual methods, ie, normal or controlled crossing followed by the planting of seeds derived from the crosses, or by vegetative methods, e.g., bud grafting. In normal practice, the trees are propagated by grafting buds from a mother tree onto the stem of a seedling. A tree derived either directly or indirectly by this method from a single mother tree is called a clone. Today, less than 100 clones are commercially grown, but many times that number have been grown experimentally. The mother tree is chosen for the best combination of a variety of characteristics, including yield, bark, various growth characteristics, and resistance to disease and wind damage.

Young rubber trees are planted in a variety of ways. The seeds can be planted in the field and the resultant seedlings budded several months later. Other approaches involve the use of nurseries where young plants are grown under careful supervision before planting. After the established seedlings are planted in the field, they can be budded at a suitable time. In another method, the seedlings are budded in the nursery and the budded stumps are transferred to a polyethylene bag filled with soil. The stumps are kept in the polybag for 4-8 weeks before being transplanted to the field. This technique prevents the planting of inferior material. Current planting practices have reduced the immature period in the field from 7 yr to 4-5 yr.

The *Hevea* tree, although robust, is subject to diseases that affect the leaves, bark, and roots. Leaf diseases include *Oidium heveae* and *Colletotrichum gloeosporioides*. Both diseases cause defoliation of the new leaves that form in March and April after the annual wintering. The most devastating leaf disease is the South American Leaf Blight caused by the fungus *Microcyclus ulei*. The disease, which is mainly confined to Central and South America, has prevented significant expansion of rubber growing in this area. Thermal fogging with a combination of fungicides provides a measure of control but is expensive. Red and White Root Diseases are caused by the attack of *Rigidoporus lignosus* and *Ganoderma pseudoferrum*, respectively. Both diseases prevent the transfer of nutrients from the soil and, if left untreated, eventually kill the tree.

Exploitation

Natural rubber occurs as particles dispersed in an aqueous serum, *i.e.*, latex, which is contained in bundles of tubular vessels in the tissue of the tree. In the trunk, these vertical bundles are inclined from right to left at an angle of ca 5°. Latex is harvested from the tree by a process called tapping, which can be described as controlled wounding of the tree. A specially designed tapping knife is used to remove shavings of bark from the surface of a groove made into the tree to a depth ca 1 mm from the cambium. The groove is made downward from left to right at an angle of ca 30° to the horizontal across half the tree. This type of cut is the most common and is called a half spiral. Conventional tapping calls for tapping the half spiral on alternate days

(tapping notation, S/2, d/2, 100%). The plantation industry is constantly searching for ways to increase yields and reduce labor costs. Since the early 1950s, there has been considerable interest in chemical stimulants to increase yields. In the early 1970s the industry settled on Ethepon (Ethrel) (2-chloroethylphosphonic acid) applied to the bark below the tapping cut. Ethepon decomposes slowly in the presence of moisture, releasing ethylene within the tissues of the bark. Through the use of Ethepon, the tapping intensity can be reduced from the half spiral every second day to half spiral every fourth day (S/2, d/4, 50%), thus reducing labor by 50% while maintaining or increasing yields. Experiments are now being conducted to determine the effects of further reducing the tapping intensity.

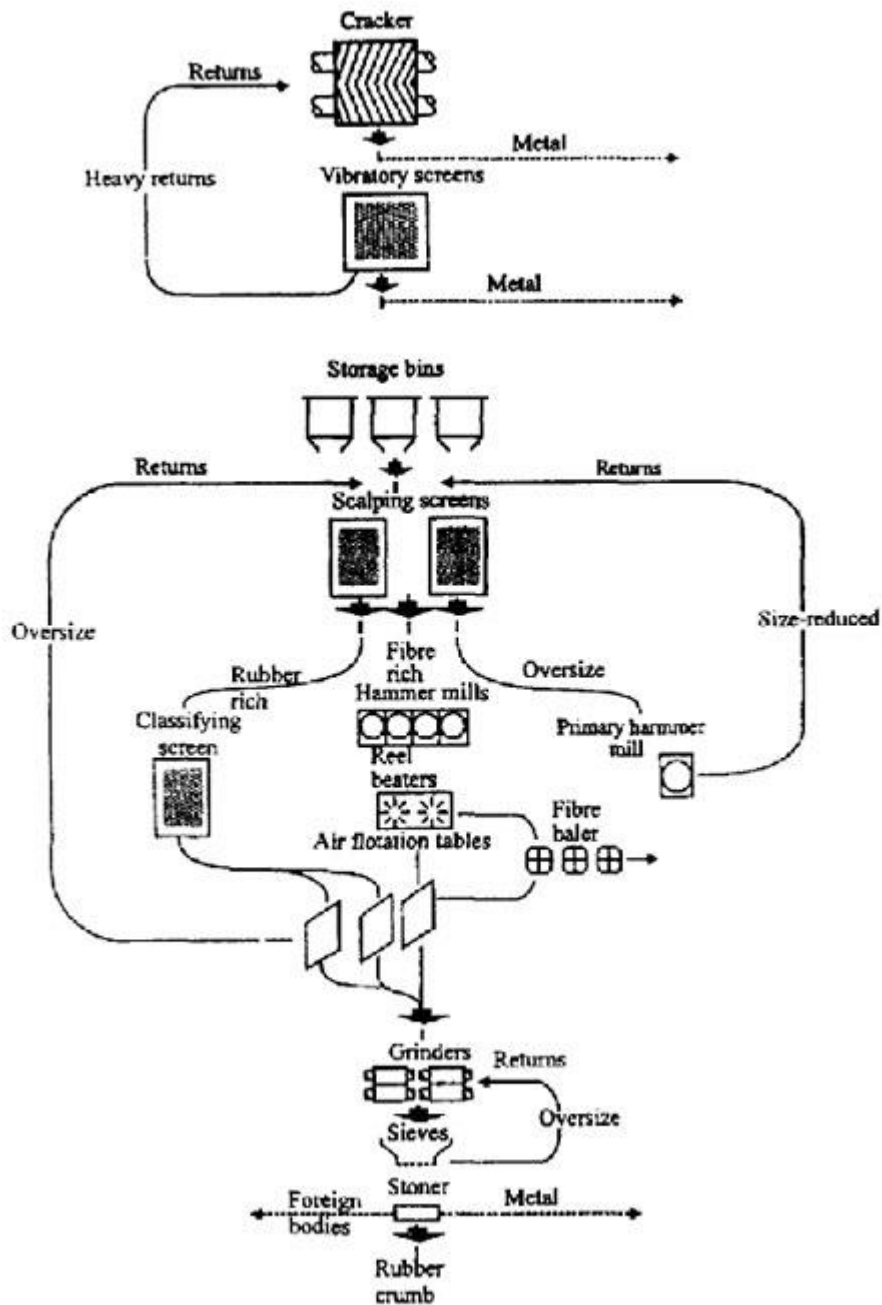

The tapper begins tapping in the morning, as soon as it is light enough to see. The cool morning air allows the latex to flow more freely. The tree is tapped with a curved tapping knife, which is V-shaped at the end. The tapper moves down the cut from left to right, carefully removing 2-3 mm of bark from the cut. The latex exudes onto the surface and flows down the cut into the collection cup; however, it becomes contaminated with bacteria soon after tapping. The bacteria attack the sugars in the latex, generating low molecular weight fatty acids. These acids lower the pH of the latex and coagulation takes place within a few hours unless preventive measures are

taken. A few drops of ammonia solution may be added to the cup prior to tapping to prevent premature coagulation. The tapper collects the latex later the same morning and takes it to a central bulking station where it is preserved further, usually with the addition of ammonia gas to ca 0.40% before transportation to the factory.

Natural rubber arrives at the processing factory as field latex or field coagula. Field coagula generated on a rubber estate consist exclusively of cup lump and tree lace. Cup lump is formed by the natural (bacterial) coagulation of latex which drips into the cup after the morning collection. Tree lace is the thin skin of rubber which forms on the tapping cut, sealing the latex vessels and stopping the flow of latex. The ratio of latex to field coagula on an estate is ca 75:25. Many smallholders are unable to bring their latex to a processing factory in liquid form because of the long distances and small quantities involved. They generate coagula in various forms: cup lumps, tree lace, slabs, large lumps, and balls. The rubber may be coagulated naturally or by adding acid, preferably formic, although sulfuric is sometimes used. Field latex and field coagula are the base raw materials for all types and grades of natural rubber.

Latex Composition

The latex of the *Hevea brasiliensis* tree has been described as a cytoplasmic system containing rubber and nonrubber particles dispersed in an aqueous serum

Freshly tapped *Hevea* latex has a pH of 6.5-7.0, a density of 0.98 g/cm³, and a surface free energy of 4.0-4.5 mJ/cm² (0.96-1.1 /mcal/cm²). The total solids of fresh field latex vary typically from 30 to 40%, depending on the clone, weather, stimulation, tapping frequency, and other factors. The dry rubber content is ca 3 wt % less than the total solids. The nonrubber portion is made up of a large number of substances with proteins and the cyclic polyol quebrachitol predominating. The solids, both rubber and nonrubber, in freshly tapped latex are distributed through three phases, which are separated by ultracentrifugation (qv). They are the top or rubber phase, the middle or serum phase, and the bottom or lutoid phase.

The rubber phase typically contains 96 wt % rubber hydrocarbon, 1 wt % protein, and 3 wt % lipids along with trace amounts of magnesium, potassium, and copper. The rubber particles are stabilized by an adsorbed layer of protein and phospholipids. Other constituents of the rubber phase include tocotrienols (free and esterified), sterols, sterol esters, fats, and waxes. The protein α -globulin is present in the highest concentration in fresh field latex. The phospholipid content varies from 0.38 to 0.8 wt % of the latex. The serum phase, sometimes referred to as the C-serum or aqueous phase, is a dilute aqueous solution with a density slightly over 1.0 g/cm³. The serum contains many different classes of compounds, including carbohydrates, proteins, amino acids, enzymes, and nitrogenous bases. The bottom fraction or lutoid phase consists mainly of lutoid particles. They were discovered when fresh latex was centrifuged at low speeds and separated into fractions. The top fraction contained most of the rubber particles, whereas the bottom fraction contained aggregates that were distinctly different. These aggregates were called lutoids because they were thought to cause the yellow color present in natural rubber. Lutoid particles contain 20 wt % water-soluble protein, of which ca 70 wt % is hevein (mol wt ca 10,000). The yellow color of the lutoid phase is caused by Frey Wyssling particles, which are spherical, nonrubber particles, whose color is due to the presence of carotenoid pigments. These pigments

give natural rubber its yellow color. The intensity of the yellow color is a clonal characteristic varying among clones.

The molecular weight and molecular weight distributions of natural rubber can be determined by gel-permeation chromatography (gpc) on fresh samples of raw latex where the gel or insoluble portion is small. Molecular weight determinations on commercial rubbers are hampered by an insoluble gel content as high as 60-70%. The number-average (Mn) and weight-average molecular weights (Mu) for 19 clones have been determined. Latex was collected from tapping cups 2-3 h after tapping and taken immediately to the laboratory without ammoniation. In order to minimize tree-to-tree variation, the latex from 8-15 trees was blended together. The molecular weight, Wallace plasticity, and Mooney viscosity for four representative clones are shown in Table 1. It was shown also that rubbers with a high initial viscosity hardened less on storage. This fact combined with the blending of clonal material during processing explains why the observed plasticity range for commercial grades of natural rubber is not as wide as would be suggested by the data in Table 1. The molecular weight distribution as determined by Mw/Mn is extremely wide for natural rubber, ca-9. Molecular weights range from 3×10^4 to an estimated upper limit of 107. The molecular weight distribution curves for natural rubber are bimodal in nature. The bimodal distribution is significant and influences strength and processibility. The high molecular weight fraction imparts strength and other important physical properties; the low molecular weight fraction contributes to processibility.

Properties of Clonal Rubber

Clone	Mn $\times 10^{-6}$	Mw $\times 10^{-5}$	Wallace plasticity, P0a	Mooney viscosity, ML (1 + 4)
RRIM 501	1.95	1.71	32	49
RRIM 600	2.58	1.93	53	72
GT 1	2.65	1.85	58	79
P/B 5/51	5.21	2.18	67	94

(a) Original plasticity

Recycling of Rubbers

INTRODUCTION

Manufacturing of tire and other rubber products involves vulcanization process, an irreversible reaction between the elastomer, sulfur, and other chemicals producing crosslinks between the elastomer molecular chains and leading to the formation of a three-dimensional chemical network. The crosslinked elastomers are solid, insoluble, and infusible thermoset materials. This makes the direct reprocessing and recycling of used tires and waste rubbers impossible. Therefore, the environmental problems caused by used tires and other waste rubber products have become serious in recent years. In fact, Charles Goodyear, who invented the sulfur vulcanization process more than 150 years ago was also the first to initiate efforts to recycle

cured rubber wastes through a grinding method. Even after so many years of efforts in recycling, the development of a suitable technology to utilize waste rubbers is an important issue facing the rubber industry.

According to a recent survey of the Scrap Tire Management Council of the Rubber Manufacturers Association, approximately 281 million scrap tires were generated in the United States in 2001 alone. The market for scrap tires is consuming about 77.6% of that total amount while the rest is added to an existing stockpile of an estimated 300 million scrap tires located around the United States. These stockpiled tires create serious fire dangers and provide breeding grounds for rodents, snakes, mosquitoes, and other pests, causing health hazards and environmental problems. Moreover, the major use of scrap tires in the United States is to generate the so-called tire-derived energy by burning used tires. However, burning tires may create a danger of air pollution. About 53% of the consumed scrap tires were burned in 2001, and only 19% of the total consumed amount was turned into ground tire rubber (GRT), which is the initial material for the tire rubber recycling processes. Also, the management of other waste rubbers has become a growing problem in the rubber industry since, over 150,000 tons or more of rubber are scrapped from the production of non-tire goods in the form of runners, trim, and pads.

Waste tires and rubbers, being made of high quality rubbers, represent a large potential source of raw material for the rubber industry. The main reasons for the low-scale current application of tire and rubber recycling include the following: more stringent requirements for quality of rubber articles, and hence for that of reclaimed rubber; the substitution of other materials for raw rubber (e.g., plastics in some cases); rising costs of recovery from tires and rubber waste due to the more stringent regulations for environmental protection; a comparatively high labor input into reclaim production; and, as a result of all this, the high cost of reclaimed rubber. However, the increasing legislation restricting landfills is demanding the search for economical and environmentally sound methods of recycling discarded tires and waste rubbers. Recent aggressive policies of the automotive industry are aimed at increasing the use of recycled plastic and rubber materials. This may serve as an example of the growing industrial demand for such technologies.

The main objective of this chapter is to provide the up-to-date account on recycling of used tires and waste rubbers including existing methods and emerging technologies of grinding, reclaiming, and devulcanization, and also the possibility for recycled rubber utilization into products. Rubber devulcanization is a process in which the scrap rubber or vulcanized waste product is converted, using mechanical, thermal, or chemical energy, into the state in which it can be mixed, processed, and vulcanized again. Strictly speaking, devulcanization in sulfur-cured rubber can be defined as the process of cleaving, totally or partially, poly-, di-, and monosulfidic crosslinks formed during the initial vulcanization. Devulcanization of peroxide- and resin-cured rubber can be defined as the process of cleaving carbon-carbon or other, stronger crosslinks. However, in the present concept, devulcanization is defined as a process that causes the breakup of the chemical network along with the breakup of the macromolecular chains.

A number of methods have been applied in an attempt to solve the problem and to find more effective ways of tire rubber recycling and waste rubber utilization. These methods include retreading, reclaiming, grinding, pulverization, microwave and ultrasonic processes, pyrolysis.

and incineration. Processes for utilization of recycled rubber are also being developed, including the use of reclaimed rubber to manufacture rubber products and thermoplastic-rubber blends and the use of GRT to modify asphalt and cement.

RETREADING OF TIRE

Retreading is one way to recycle. Also, it saves energy. It takes about 83 liters of oil to manufacture one new truck tire whereas a retread tire requires only about 26 liters. The cost of a retread tire can be from 30 to 50% less than "a new tire. Approximately 24.2 million retreaded tires were sold in North America in 2001. with sales totaling more than \$2 billion. Mostly medium-and heavy-duty truck tires, off-the-road vehicles, and aircraft tires "were retreaded. However, high labor costs and the potential for tougher safety regulations may hurt the retreading business.

RECYCLING OF RUBBER VULCANIZATES

Reclaiming Technology

Reclaiming is a procedure in which the scrap tire rubber or vulcanized rubber waste is converted, using mechanical and thermal energy and chemicals, into a state in which it can be mixed, processed, and vulcanized again. The principle of the process is devulcanization. In devulcanization, it is assumed that the cleavage of intermolecular bonds of the chemical network, such as carbon-sulfur and/or sulfur-sulfur bonds, takes place, with further shortening of the chains occurring.

Many different reclaiming processes have been applied through the years in an attempt to solve the problem of rubber recycling. Generally, ground rubber scrap is in most cases, the feedstock for the devulcanization step. Warner and recently Adhikari et al., and Isayev presented reviews of the existing literature that is relevant to various methods of devulcanization.

Reclaiming is the most important process in rubber recycling. Many different reclaiming processes have been used through the years depending on scrap characteristics and economics. Generally, ground rubber scrap is, in most cases, the feedstock for the reclaiming. The pan process, digester process (either wet or dry), and mechanical or reclaimator processes are currently the common processes used for reclaiming.

The digester process uses a steam vessel equipped with a paddle agitator for continuous stirring of the crumb rubber while steam is being applied. The wet process may use caustic and water mixed with the rubber crumb, while the dry process uses steam only. If necessary, various reclaiming oils may be added to the mixer in the vessel. The dry digester has the advantage of less pollution being generated and was adopted after the Clean Air and Water Act was enacted.

A mechanical or reclaimator process has been used for the continuous reclaiming of whole tire scrap. Fine rubber crumb (typically 30 mesh) mixed with various reclaiming oils is subjected to high temperature with intense mechanical working in a modified extruder for reclaiming the rubber scrap.

Scrap rubber containing natural and synthetic rubbers can be reclaimed by digester process with the use of reclaiming oil having molecular weight between 200 and 1000 and consisting of benzene, alkyl benzene, and alkylate indanes. The composition of this reclaiming oil and the improved digester process using such reclaiming oil has been patented.

Recently, a new technology for the devulcanization of sulfur-cured scrap elastomers was reported using a material termed "Delink". Such technique of devulcanization was designated as Delink process. In this process, 100 parts of 40-mesh or finer crumb is mixed with 2 to 6 parts of Delink reactant in an open two-roll mixing mill. Delink reactant is a proprietary material, and its nature and composition was not disclosed.

A simple process for reclaiming of rubber with a vegetable product that is a renewable resource material (RRM) was developed. The major constituent of RRM is diallyl disulfide. Other constituents of RRM are different disulfides, monosulfides, polysulfides, and thiol compounds.

It is known that sulfur-vulcanized Natural Rubber (NR) can be completely recycled at 200 to 225°C by using diphenyldisulphide. Recently, the efficiency of various disulphides as recycling agents for NR and EPDM vulcanizates were reported. While complete devulcanization was observed on sulfur-cured NR at 200°C, a decrease in crosslink density of 90% was found when EPDM sulfur vulcanizates with diphenyldisulphide were heated to 275°C in a closed mold for 2 hours. At the same time, EPDM cured by peroxide showed a decrease in crosslink density of about 40% under the same conditions.

Another chemical method was recently proposed. It is based on the use of 2-butanol solvent as a devulcanizing agent for sulfur-cured rubber under high temperature and pressure. It is claimed that the molecular weight of the rubber is retained, and its microstructure is not significantly altered during the devulcanization process. However, the process is extremely slow and requires separation of the devulcanized rubber from the solvent.

In addition to the use of organic chemicals, rubbers can be devulcanized by means of inorganic compounds. Discarded tires and tire factory waste were devulcanized by desulfurization of suspended rubber vulcanizate crumb (10 to 30 mesh) in a solvent such as toluene, naphtha, benzene, cyclohexane, etc. in presence of sodium. The alkali metal cleaves mono-, di-, and polysulfidic crosslinks of the swollen and suspended vulcanized rubber crumb at around 300°C in absence of oxygen. However, this process may not be economical because the process involves swelling of the vulcanized rubber crumb in an organic solvent where the metallic sodium in molten condition should reach the sulfidic crosslink sites in the rubber crumb. Also, the solvent may cause pollution and be hazardous. A technology was also proposed to reclaim powder rubbers using an iron oxide phenyl hydrazine based catalyst and a copper (I) chloride-tributyl amine catalyst.

Depending on the specification of the finished products, fillers may be added to the devulcanized product before further processing. The devulcanized rubber from each process is then strained and refined as dictated by the specification of the finished product before being powdered, baled, sheeted, or extruded into the finished form.

Chemical reclaiming process is a possible method for devulcanizing the vulcanized network through the use of chemical agents that attack the C-S or S-S bonds. However, this process of devulcanization is very slow and creates further problems with the removal of the solvents, and additional waste is generated in the form of sludges. Also, some processes require elaborate chemical process techniques, therefore handling and safety become a concern.

Surface Treatment

Surface treatment technology uses a solvent to treat (devulcanize) the surface of rubber crumb particles of sizes within about 20 to 325 meshes. It is a variation of earlier disclosed technology. The process is carried out at a temperature range of between 150 and 300°C at a pressure of at least 3.4 MPa in the presence of a solvent selected from the group consisting of alcohols and ketones. Among various solvents, the 2-butanol exhibited the best ability to devulcanize sulfur-cured styrene-butadiene rubber (SBR). Duration of the process is above 20 minutes.

Reported data on surface devulcanization experiments were obtained by treating small amounts of rubber crumb in the gas chromatography column. The solvent suitable for this process should have a critical temperature in the range of about 200 to 350°C. The process produces slurry of the surface devulcanized rubber crumb that has to be separated from the solvent. It is claimed that in this process a preferential breakage of S-S and C-S bonds takes place with little breakage of the main chains. The obtained surface modified rubber crumb was subjected to vulcanization as obtained and also in blends with virgin rubber. The vulcanizates exhibited a good retention of mechanical properties in blends with virgin rubber. However, this process has been tested on a small laboratory scale.

Grinding and Pulverization Technology

Use of waste rubber in a vulcanized state most often requires reduction of particle size and/or surface area. One of the most widely used methods for doing this with scrap tires and rubber wastes is a grinding process. This method was invented and put forward by Goodyear about 150 years ago. Presently, there are three methods of grinding waste rubber: ambient grinding, cryogenic grinding, and wet-ambient grinding. There are a number of ways to reduce tires. The primary reduction of whole tires down to a manageable form is done using the guillotine, the cracker mill, the high-impact hammer mill, and the rotary shear shredder. Vulcanized scrap rubber is first reduced to a 5-by-5-cm or 2.5-by-2.5-cm² chip. Then a magnetic separator and a fiber separator (cyclone) remove all the steel and polyester fragments. This can then be further reduced using an ambient ground mill or ground into fine particles while frozen using cryogenic grinding.

A method for obtaining fine-mesh rubber is cooling scrap tires in liquid nitrogen below their glass transition temperature and then pulverizing the brittle material in a hammer mill. Cryogenically ground rubber has a much finer particle size, varying from 30 to 100 mesh. But for inexpensive rubbers such as tire rubbers, the process is not economical because of the amount of liquid nitrogen or other cryogen liquids needed to freeze the rubber. However, the process may be economical for expensive rubbers such as fluorocarbon rubbers. Little or no heat is generated in the process; this results in less degradation of the rubber. In addition, the most

significant feature of the process is that almost all fiber or steel is liberated from the rubber, resulting in a yield of usable product and little loss of rubber.

Because of the high cost of cryogenic size reduction at liquid nitrogen temperature, mechanical size reduction by chopping and grinding is used often. The ambient process often uses a conventional high-powered rubber mill set at close nip. The vulcanized rubber is sheared and ground into small particles. Using this relatively inexpensive method, it is common to produce 10- to 30-mesh material and relatively large crumb. In addition, multiple grinds can be used to further reduce the particle size. Ambient grinding produces an irregular-shaped particle with many small hairlike appendages that attach to the virgin rubber matrix, producing an intimate bonded mixture. The lower particle limit for the process is the production of 40-mesh material. The process, however, generates a significant amount of heat. Excess heat can degrade the rubber, and if not cooled properly, combustion can occur upon storage.

Other suggested recycling processes include mechanical and thermomechanical methods, which only comminute the vulcanizates in rubber and do not devulcanize them. A process using a wet grinding method to achieve a crumb fineness of approximately 200 mesh has been reported. When this product, which had a much higher surface-to-mass ratio, was devulcanized, no chemicals and only minimal heating and mechanical processing were required. Wet or solution process grinding may yield the smallest particle size, ranging from 400 to 500 mesh. The advantage of fine particle wet ground rubber is that it allows good processing, producing relatively smooth extrudates and calendered sheets.

The pulverization techniques for rubbers are also being developed based on the concept of polymer pulverization originally proposed for plastics. The process manufactures polymer powder using a twin-screw extruder imposing compressive shear on the polymer at specific temperatures that depend on the polymer. Based on this method, the solid-state shear extrusion pulverization method of rubber waste was also proposed. The obtained rubber particles were fluffy and exhibited unique elongated shape.

Recently, this process was further developed to carry out pulverization of rubbers in a single screw extruder to obtain particles varied in size from 40 to 1700 μm . A schematic diagram of the pulverization technique based on a single screw extruder is shown in Figs. 1(a) and 1(b). As indicated in Fig. 1(a), the extruder consists of three zones: feeding (Zone 1), compression (Zone 2), and pulverization (Zone 3). The screw is a square pitched with the compression zone having a uniform taper to create a compression ratio of 5. The water-cooling channel is located in the barrel in order to remove the heat generated by the pulverization of rubber. Experimental studies showed that during the pulverization of vulcanized scrap rubber in the extruder, due to friction, a significant amount of heat is generated, leading to partial degradation of the rubber. The rubber granulates are fed into the hopper of the extruder and conveyed into the compression zone, where they are subjected to high compressive shear. Under simultaneous action of this compressive shear and torsion due to the screw rotation, granulates are pulverized and emerge from the pulverization zone as rubber powder having a smaller particle size.

Surface oxidation of the rubber particles and initiation of agglomeration of a fraction of the produced particles may take place. The produced particles exhibit irregular shapes with rough

surfaces and have a porous structure. The crosslink density and gel fraction of the particles are reduced in comparison with those of the initial rubber granulates. This would indicate the occurrence of partial devulcanization. Due to this effect, the particles obtained in this process can be molded into products after an exposure to high heat and high pressure for a period of at least 1 hour. Table 1 shows the dependence of the elongation at break, e_b , tensile strength, s_b , and crosslink density, v , of compression-molded slabs of the original rubber vulcanizate and the vulcanizates prepared from particles of size in the range 250 to 425 μm obtained by solid-state shear extrusion pulverization from discarded by-product of natural rubber (SMR-20) vulcanizates. Approximate composition of the rubber compound was about 54 wt% of SMR-20, 27 wt% carbon black (SRF), 11 wt% aromatic oil, and 8 wt% vulcanizing ingredients. Molding temperature and pressure were 157°C and 5.11 MPa, respectively. Slab F1, produced without adding sulfur curatives, exhibited the best failure properties among all slabs produced from the rubber powder. In Sample F1 oil, vulcanizing residue and the sol fraction of the rubber were removed by toluene extraction. This, according to the authors, enhanced particle bonding, leading to improvement of the failure properties. On the other hand, the slabs F2 and F3 produced by adding sulfur curatives to particles showed inferior failure properties than those of slab F1 due to less particle bonding at increased crosslink density during the revulcanization. Furthermore, the slabs F1-F3 showed failure properties inferior to the original slab indicating the inadequacy of compression molding of rubber particles to achieve the properties of the original vulcanizate.

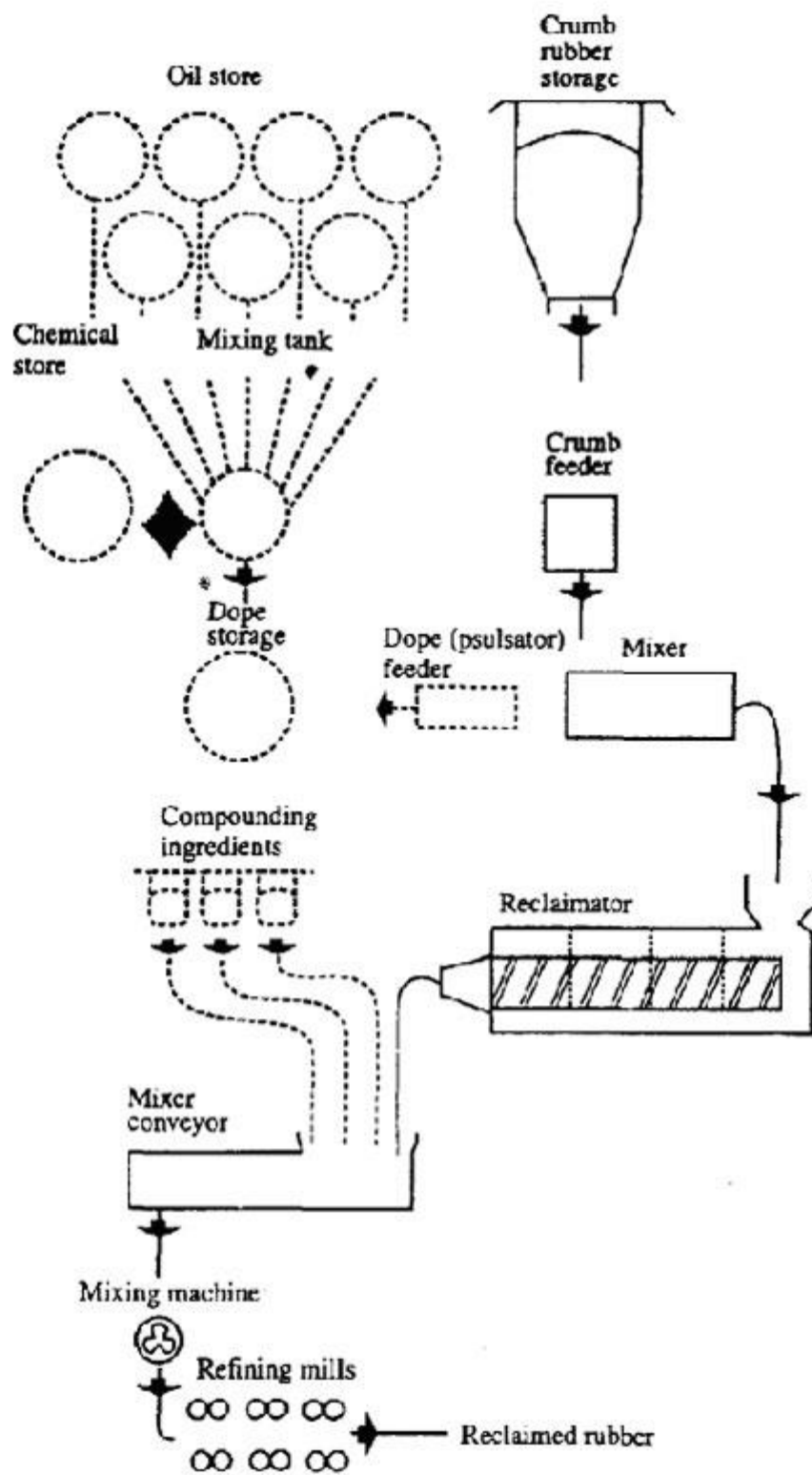

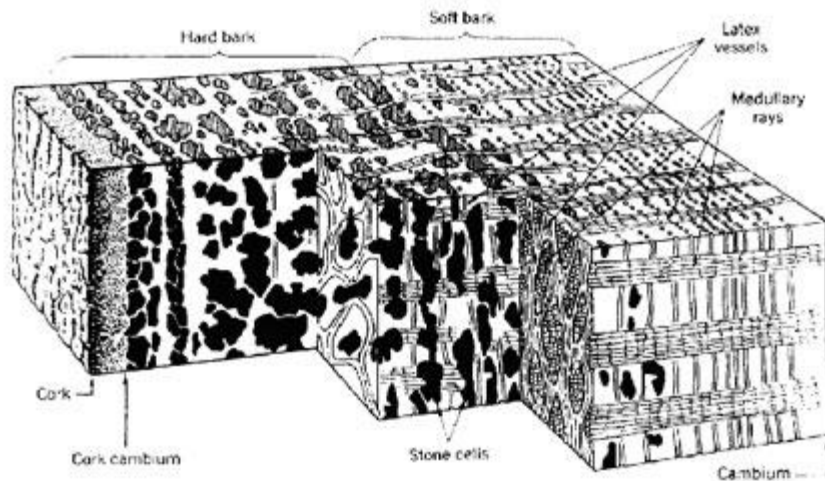

The particles obtained by other grinding processes can also be compression molded into slabs by means of high-pressure, high-temperature sintering as shown in Morin et. al. and Tripathy et al. In particular, in these papers, rubber particles of several rubbers, obtained by various grinding methods, were compression molded into slabs with and without an addition of various acids and chemicals.

The effect of time, pressure, and temperature on mechanical properties of sintered slabs was studied. In particular, Fig. 2 shows the effect of molding temperature on mechanical properties of NR-SBR slab compression molded from particles of 80 mesh for 1 hour at pressure of 8.5.MPa. It clearly shows the importance of the molding temperature. Below approximately 80° C, this process does not work. The highest tensile strength of about 4MPa was achieved with the sufficiently high elongation at break (about 800%). The mechanism of consolidation of particles in this process is the result of the breakup of bonds into radicals that cross the particle interface and react with other radicals and thus create a chemical bond across the interface. The authors explained that the inferior properties of the sintered NR particle slabs in comparison with the original one was due to the energetics between void propagation and strain-induced crystallization. Less energy is required to generate voids in the sintered slabs than in the original slab, and this does not allow one to achieve a strain-induced crystallization in the sintered slabs.

DEVULCANIZATION TECHNOLOGY

Microwave Method

Microwave technology has also been proposed to devulcanize waste rubber. This process applies the heat very quickly and uniformly on the waste rubber. The method employs the application of a controlled amount of microwave energy to devulcanize a sulfur-vulcanized elastomer, containing polar groups or components, to a state in which it could be compounded and re-vulcanized to useful products, such as hoses, requiring significant physical properties. On the basis of the relative bond energies of carbon-carbon, carbon-sulfur, and sulfur-sulfur bonds, it

was presumed that the scission of the sulfur-sulfur and sulfur-carbon crosslinks actually occurred. However, the material to be used in the microwave process must be polar enough to accept energy at a rate sufficient to generate the heat necessary for devulcanization. This method is a batch process and requires expensive equipment.

Recently, thermogravimetry was employed to study the changes occurring in rubber vulcanizates during devulcanization carried out by microwave treatment. The degree of degradation of the polymer chains in response to microwave treatment was obtained, allowing the establishment of conditions of devulcanization in order to obtain the best properties of rubber devulcanizates for reuse in rubber processing.

Ultrasonic Method

Numerous publications in recent literature are devoted to the study of the effect of ultrasound on polymer solutions and on polymer melts during extrusion. Significant efforts have also been made to understand the mechanism of the effect of ultrasound on fluids and degradation of polymer in solution.

The application of ultrasonic waves to the process of devulcanizing rubber is an attractive field of study. Most references indicate that rubber is vulcanized by ultrasound rather than devulcanized. Rubber devulcanization by using ultrasonic energy was first discussed in Okuda and Hatano. It was a batch process in which a vulcanized rubber was devulcanized at 50 kHz ultrasonic waves after treatment for 20 minutes. The process claimed to break down carbon-sulfur bonds and sulfur-sulfur bonds, but not carbon-carbon bonds. The properties of the devulcanized rubber were found to be very similar to those of the original vulcanizates.

Recently, a novel continuous process has been developed for devulcanization of rubbers as a suitable way to recycle used tires and waste rubbers. This technology is based on the use of high-power ultrasounds. The ultrasonic waves of certain levels, in the presence of pressure and heat, can quickly break up the three-dimensional network in crosslinked rubber. The process of ultrasonic devulcanization is very fast, simple, efficient, and solvent and chemical free. Devulcanization occurs at the order of a second and may lead to the preferential breakage of sulfidic crosslinks in vulcanized rubbers. The process is also suitable for decrosslinking of the peroxide-cured rubbers and plastics. A schematic diagram of the various devulcanization reactors suitable to carry out this process is shown in Fig. 3. Initially, the so-called coaxial devulcanization reactor was developed in our laboratory. The reactor consists of a single screw rubber extruder and an ultrasonic die attachment. A cone-shaped die and the ultrasonic horn have sealed inner cavities for running water for cooling. The shredded rubber is fed into the extruder by a feeder with adjustable output. Thus, the rubber flow rate in the process is controlled by the feed rate. An ultrasonic power supply, an acoustic converter, booster, and a cone-tipped horn are used. The horn vibrates longitudinally with a frequency of 20 kHz and various amplitudes. The ultrasonic unit is mounted onto the extruder flange. The convex tip of the horn matches the concave surface of the die so that the clearance between the horn and the die is uniform. The clearance is controlled. The rubber flows through the clearance and under the action of ultrasonic waves, propagating perpendicular to the flow direction, and it is devulcanized. The die plate and the horn are cooled with tap water.

Later, the barrel and the grooved barrel ultrasonic reactors were developed. In the barrel reactor, two ultrasonic water-cooled horns of rectangular cross-sections were inserted into the barrel through two ports. Two restrictors made of bronze were placed in the barrel. These restrictors blocked the flow of rubber and forced the rubber to flow through the gap created between the rotating screw and the tip of the horn. In the devulcanization section, the larger diameter provided the converging flow of the rubber to the devulcanization zone. The latter may enhance the devulcanization process, in the grooved barrel ultrasonic reactor, two helical channels were made on the barrel surface (grooved barrel). Rubber flows into the helical channel and passes through the gap created between the rotating shaft and the tip of the horns, where devulcanization takes place.

Under the license from the University of Akron for the ultrasonic devulcanization technology, NFM Co. of Massillon, Ohio, has built a prototype of the machine for ultrasonic devulcanization of tire and rubber products. It was reported that retreaded truck tires containing 15 wt% and 30 wt% of ultrasonically devulcanized carbon-black-filled SBR had passed the preliminary dynamic endurance test.

Extensive studies on the ultrasonic devulcanization of rubbers and some preliminary studies on ultrasonic decrosslinking of crosslinked plastics were carried out. It was shown that this continuous process allows one to recycle various types of rubbers and thermosets. As a most desirable consequence, ultrasonically devulcanized rubber becomes soft, therefore making it possible for this material to be reprocessed, shaped, and revulcanised in very much the same way as the virgin rubber. This new technology has been used successfully in the laboratory to devulcanize a ground tire rubber (GRT), unfilled and filled NR, guayule rubber unfilled and filled SBR, unfilled and filled peroxide-cured silicone rubber, unfilled and filled EPDM and EPDM roofing membrane, unfilled polyurethane, unfilled resin-cured butyl rubber, used tire curing bladder fluoroelastomer, ethylene vinyl acetate form, and crosslinked polyethylene. After revulcanization, rubber samples exhibit good mechanical properties, which in some cases are comparable to or exceeding those of virgin vulcanizates.

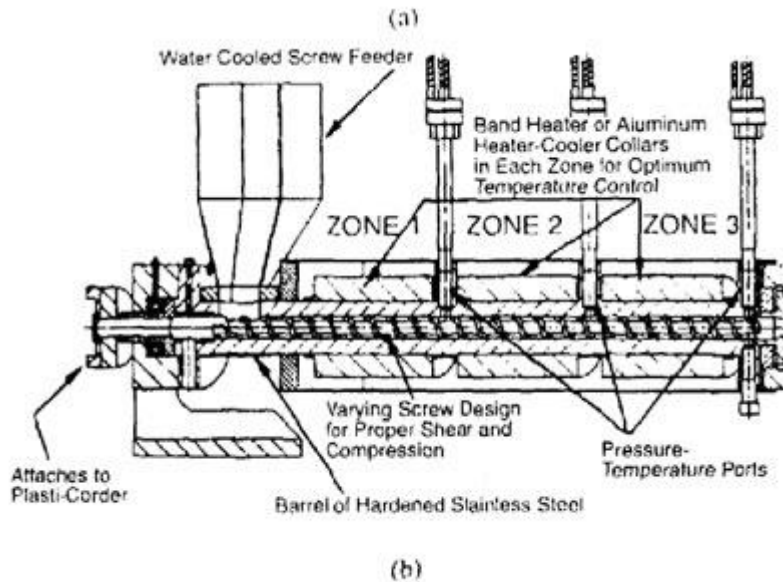

Ultrasonic devulcanization studies were concerned with finding the effect of processing parameters such as the pressure, power consumption, die gap, temperature, flow rate, and ultrasonic amplitude on devulcanization; structural changes occurring in various rubbers: rheological properties and curing kinetics of devulcanized rubbers: mechanical properties of redevulcanized rubbers; and the effect of design of the devulcanization reactor. Figure 4 shows the entrance pressure of devulcanization zone vs. amplitude of ultrasound at a flow rate of 0.63 g/s, and the entrance pressure of devulcanization zone vs. flow rate at the amplitude of 10 mm and clearance of 2mm during devulcanization of GRT. The entrance pressure of the devulcanization zone was substantially reduced as the amplitude of ultrasound was increased. Ultrasound facilitated the flow of rubber through the gap not only because of reduction of the friction in the presence of ultrasonic waves but also because of the devulcanization taking place as GRT particles entered the devulcanization zone. The barrel reactor showed a higher pressure in the devulcanization zone than the coaxial reactor, and the grooved barrel reactor showed the lowest pressure at low amplitude of ultrasound and a flow rate of 0.63 g/s. The barrel reactor had a converging zone before the devulcanization zone. The GRT flow was essentially blocked by the restrictor of the devulcanization zone at low amplitude of ultrasound. However, at the ultrasound amplitude of 10 mm, the entrance pressure of the devulcanization zone for the coaxial and barrel reactors was almost the same due to a reduction of restrictor effect at high amplitude. The highest flow rate achieved in the barrel and grooved barrel reactors was 6.3 g/s. The devulcanized sample of flow rate of 6.3 g/s for the coaxial reactor could not be obtained due to an overload of the ultrasonic generator. Furthermore, in the grooved barrel reactor, at a flow rate of 6.3 g/s. the gap size needed to be increased to 3.5 mm. and ultrasonic amplitude needed to be decreased to 6 mm due to an overload of the ultrasound unit. It was natural that the entrance pressure of the devulcanization zone rises with increasing flow rate as indicated in Fig. 4 for all three reactors. Nevertheless, at a high flow rate the barrel reactor had lower entrance pressure at the devulcanization zone than that of the other reactors at the ultrasound amplitude of 10 mm. The difference in die characteristics (pressure vs. flow rate) among the three reactors having the devulcanization zone thickness of 2mm was possibly related to the difference in power

consumption and the difference in shearing conditions. In the barrel and grooved barrel reactor, the GRT in the devulcanization zone was subjected to a pressure and drag flow while in the coaxial reactor to a pressure flow alone.

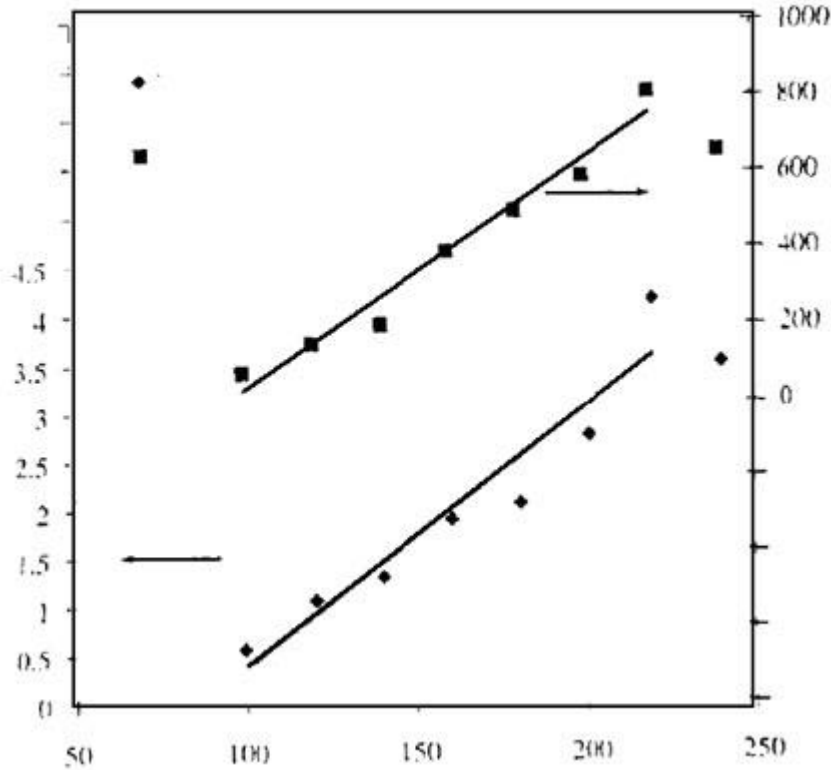

The comparison of stress-strain behavior of the vulcanizates prepared from devulcanized GRT produced by the three reactors at the maximum flow rate is shown in Fig. 5. The revulcanized sample obtained from the barrel reactor, having a flow rate of 6.3 g/s, shows a tensile strength of 8.7 MPa, elongation at break of 217%, and modulus at 100% elongation of 2.6 MPa. In addition, the revulcanized sample obtained from the grooved barrel reactor having, a flow rate of 6.3 g/s, shows the tensile strength of 8.3 MPa, the elongation at break of 184%, and modulus at 100% elongation of 3.3 MPa. The output of the barrel and grooved barrel reactors was higher than that of the coaxial reactor. In addition, the mechanical properties of the sample obtained using the barrel reactor at the higher flow rate, which could not be achieved in the coaxial reactor, were higher. These properties met the higher level of specification made for tire reclaim. The samples showing inferior performance were considered overtreated. The overtreatment meant a higher degree of devulcanization along with a significant degradation of the backbone molecular chains. The overtreated samples were usually softer and stickier.

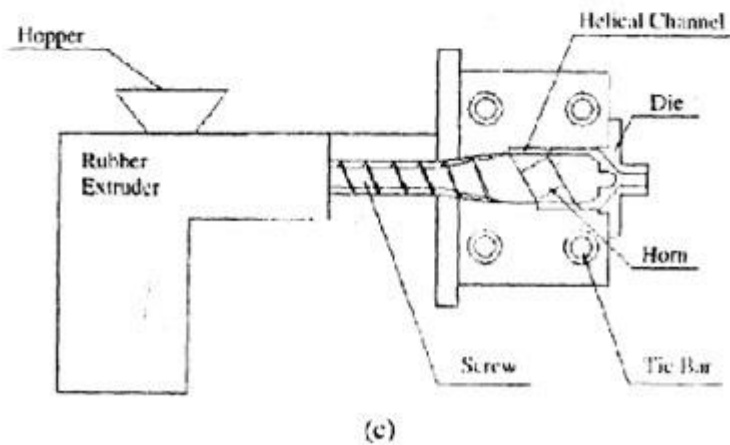
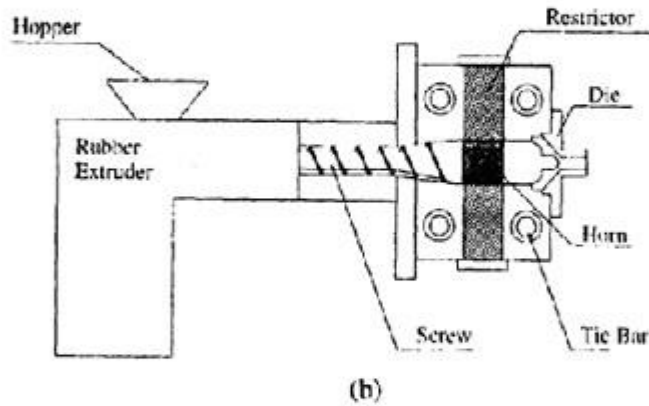
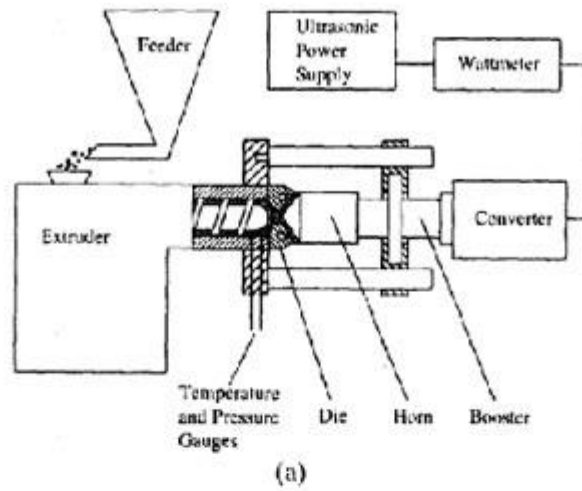

It is believed that the process of ultrasonic devulcanization is based on a phenomenon called cavitation. In this case, acoustic cavitation occurs in a solid body. This is in contrast to the cavitation typically known to occur in liquids in the regions subjected to rapidly alternating pressures of high amplitude generated by high-power ultrasonics. During the negative half of the pressure cycle, the liquid is subjected to a tensile stress, and during the positive half cycle, it

experiences a compression. Any bubble present in the liquid will thus expand and contract alternately. The bubble can also collapse suddenly during the compression. This sudden collapse is known as cavitation and can result in almost instantaneous release of a comparatively large amount of energy. The magnitude of the energy released in this way depends on the value of the acoustic pressure amplitude and, hence, the acoustic intensity.

Although the presence of bubbles facilitates the onset of cavitation, it can also occur in gas free liquids when the acoustic pressure amplitude exceeds the hydrostatic pressure in the liquid. For a part of the negative half of the pressure cycle, the liquid is in a state of tension. Where this occurs, the forces of cohesion between neighboring molecules are opposed, and voids are formed at weak points in the structure of the liquid. These voids grow in size and then collapse in the same way gassed bubbles do. Cavitation may be induced in a gas-free liquid by introducing defects, such as impurities, in its lattice structure.

In the case of polymer solutions, it is well known that the irradiation of a solution by ultrasound waves produces cavitation of bubbles. The formation and collapse of the bubble plays an important role in the degradation of polymers in solution. Most of the physical and chemical effects caused by ultrasound are usually attributed to cavitation: the growth and very rapid, explosive collapse of microbubbles as the ultrasound wave propagates through the solution. The intense shock wave radiating from a cavitating bubble at the final stage of the collapse is undoubtedly the cause of the most severe reactions. This shock wave is capable of causing the scission of macromolecules that lie in its path. The degradation arises as a result of the effect of the ultrasound on the solvent. In any medium, cavities, voids, and density fluctuations exist. It is believed that these induce cavitation, leading to molecular rupture. In solid polymers, the microvoids, present intrinsically, are responsible for cavitation when they are subjected to a hydrostatic pressure in the manner of an impulse. One of the main causes of microvoid generation in polymer materials is the interatomic bond rupture when they are subjected to mechanical and thermal stresses. Extensive studies showing microvoid formation in stressed polymers have been carried out.

When applied to rubbers, the cavitation usually corresponds to the effect of formation and unrestricted growth of voids in gas-saturated rubber samples after a sudden depressurization. In general, this has a broader sense and may be understood as the phenomena related to the formation and dynamics of cavities in continuous media. In materials science, for example, it means a fracture mode characterized by formation of internal cavities. In acoustics, the cavitation denotes the phenomena related to the dynamics of bubbles in sonically irradiated liquids.

Structural studies of ultrasonically treated rubber show that the breakup of chemical crosslinks is accompanied by the partial degradation of rubber mechanism of rubber devulcanization under ultrasonic treatment is presently not well understood, unlike the mechanism of the degradation of long-chain polymer in solutions irradiated with ultrasound. Specially, the mechanisms governing the conversion of mechanical ultrasonic energy to chemical energy are not clear. However, it has been shown that devulcanization of rubber under ultrasonic treatment requires local energy concentration, since uniformly distributed ultrasonic energy among all chemical bonds is not capable of rubber devulcanization.

It is well known that some amounts of cavities or small bubbles are present in rubber during any type of rubber processing. The formation of bubbles can be nucleated by precursor cavities of appropriate size. The proposed models were based on a mechanism of rubber network break down caused by cavitation, which is created by high-intensity ultrasonic waves in the presence of pressure and heat. Driven by ultrasound, the cavities pulsate with amplitude depending mostly on the ratio between ambient and ultrasonic pressures (acoustic cavitation).

It is known that, in contrast to plastics, rubber chains break down only when they are fully stretched. An ultrasonic field creates high-frequency extension-contraction stresses in crosslinked media. Therefore, the effects of rubber viscoelasticity have been incorporated into the description of dynamics of cavitation. The devulcanization of the rubber network can occur primarily around pulsating cavities due to the highest level of strain produced by the powerful ultrasound.

Generally, cleavage in polymer chains results in the production of macro-radicals, the existence of which have been confirmed spectroscopically by the use of radical scavengers such as diphenyl picrylhydrazyl (DPPH). Obviously, in the absence of scavengers, the macroradicals are free to combine by either disproportionation or combination termination, the former leading to smaller-sized macromolecules while the latter will give a distribution dependent on the size of the combining fragments.

It was reported that under some devulcanization conditions the tensile strength of unfilled revulcanized SBR was found to be much higher than that of the original vulcanizate, with elongation at break being practically intact. In particular, Fig. 6 shows the stress-strain curves of unfilled virgin vulcanizates and revulcanized SBR obtained from devulcanized rubbers at various values of ultrasonic amplitudes, A . The devulcanized rubbers were obtained by using the coaxial ultrasonic reactor depicted in Fig. 3(a) at the barrel temperature of 120°C, screw speed of 20 rpm, and flow rate of 0.63 g/s. The ultrasonic horn diameter was 76.2 mm. In contrast to usual findings that the mechanical properties of reclaimed rubber obtained by using different techniques are inferior to those of virgin vulcanizates, the present data are rather unexpected. It was proposed that the improvement in the mechanical properties of revulcanized SBR was primarily due to the extent of nonaffine deformation of the bimodal network that appears in the process of revulcanization of ultrasonically devulcanized rubber. The superior properties of revulcanized rubbers were also observed in the case of unfilled EPDM and silicone rubbers. Unfilled revulcanized NR rubber also shows good properties, with the elongation at break remaining similar to that of the original NR vulcanizates but with the ultimate strength being about 70% of the original NR. Interestingly, the strain-induced crystallization typical for the original NR vulcanizate remained intact in revulcanized NR, as indicated in Fig. 7, where upturn of the stress-strain curves is observed in both the original and revulcanized rubbers. These samples were devulcanized in a coaxial reactor at different flow rates and ultrasonic amplitudes and revulcanized with a recipe consisting of 2.5 phr ZnO, 0.5 phr stearic acid, and 2 phr sulfur.

Fillers play an interesting role in the devulcanization process. Figure 8 shows the stress strain curves for virgin and devulcanized 35 phr carbon-black-filled NR vulcanizates. Virgin vulcanizates were cured using 5 phr ZnO, 1 phr stearic acid, 1 phr CBS, and 2 phr sulfur. The revulcanization recipe contained 2.5 phr ZnO, 0.5 phr stearic acid, 0.5 CBS, and 2 phr sulfur.

The experiments have shown that upon filling rubbers with carbon black, after devulcanization the mechanical properties of revulcanized rubbers typically deteriorate, with the level of deterioration depending on the devulcanization conditions. This is clearly evident from Fig. 8. It was suggested that ultrasonic devulcanization causes a partial deactivation of filler due to the breakup of the macromolecular chains attached to the surface of carbon black. In many cases, this effect leads to inferior properties of revulcanized carbon-black-filled rubbers. Thus ultrasonically devulcanized rubber was blended with virgin rubber. The blend vulcanizates indicated significantly improved properties. Also, attempts were made to add a certain amount of a fresh carbon black into the devulcanized rubber. It was shown that the vulcanizates containing a fresh carbon black exhibited better properties than the revulcanized rubber that did not contain an addition of fresh carbon black. However, in some cases, even carbon-black-filled devulcanized rubber shows mechanical properties similar to or better than the original rubber. In particular, this was shown for an EPDM roofing membrane containing carbon black and a significant amount of oil. Apparently, oil plays an important role in the devulcanization process. Possibly, the presence of oil prevents a deactivation of the filler that was observed in vulcanizates not containing oil. But in order to prove this hypothesis, further experiments are required.

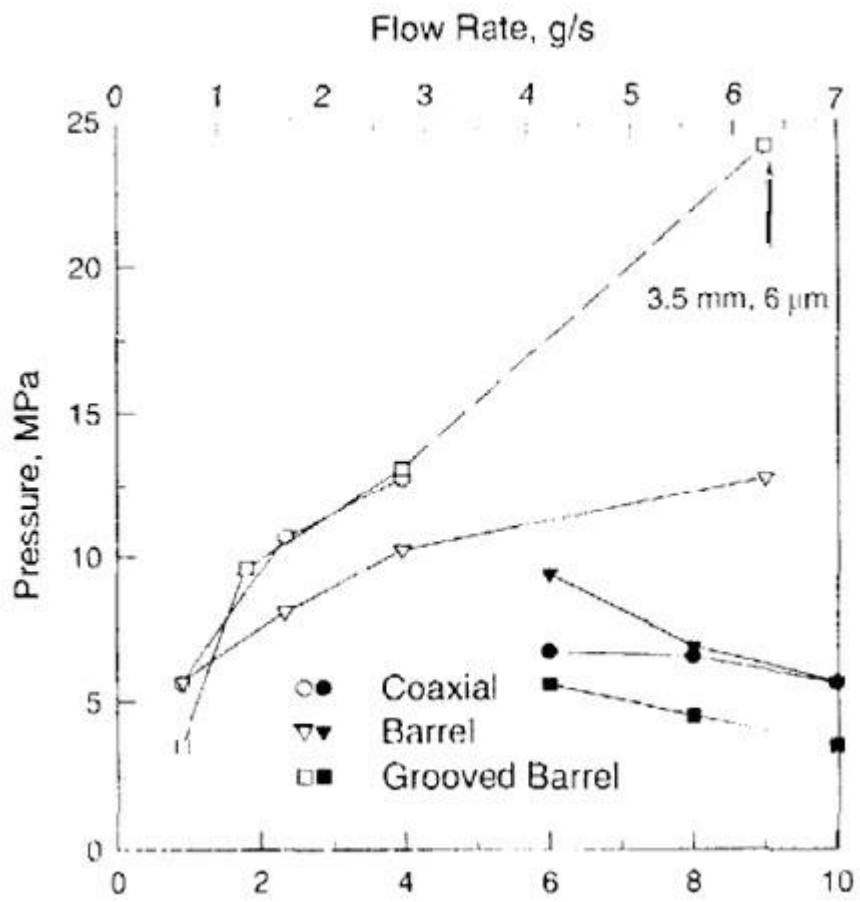

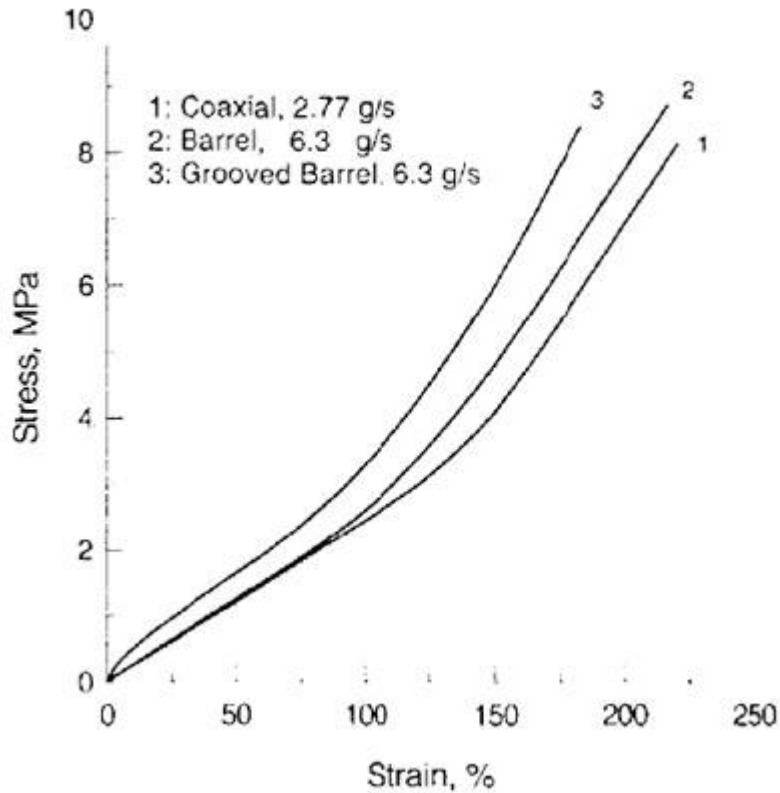

Ultrasonic devulcanization also alters revulcanization kinetics of rubbers. It was shown that the revulcanization process of devulcanized SBR was essentially different from that of the virgin SBR. The induction period is shorter or absent for revulcanization of the devulcanized SBR. This is also true for other unfilled and carbon-black-filled rubbers such as GRT, SBR, NR, EPDM, and BR cured by sulfur-containing curative systems, but not for silicone rubber cured by peroxide. It was suggested that a decrease or disappearance of the induction period in the case of the sulfur-cured rubbers is due to an interaction between the rubber molecules chemically modified in the course of devulcanization and unmodified rubber molecules, resulting in crosslinking. It was shown that approximately 85% of the accelerator remained in the ultrasonically devulcanized SBR rubber.

Ultrasonically devulcanized rubbers consist of sol and gel. The gel portion is typically soft and has significantly lower crosslink density than that of the original vulcanizate. Due to the presence of sol, the devulcanized rubber can flow and is subjected to shaping. Crosslink density and gel fraction of ultrasonically devulcanized rubbers was found to correlate by a universal master curve. This curve is unique for every elastomer due to its unique chemical structure. Figure 9 presents the normalized gel fraction as a function of normalized crosslink density of devulcanized GRT obtained from three different reactors. The gel fraction and crosslink density of GRT was 0.82 and 9.9×10^{-2} kmol/m³, respectively. For each reactor, the dependence of gel fraction on crosslink density was described by a unique master curve that was independent of processing conditions such as flow rate (residence time) and amplitude. The unique correlation

between gel fraction and crosslink density obtained in the barrel and grooved barrel reactors was shifted toward lower crosslink density than those obtained in the coaxial reactor, indicating a better efficiency of devulcanization. It is considered possible that the additional shearing effect caused by the screw rotation in the barrel and grooved barrel reactors had a positive influence on improving the efficiency of devulcanization.

USE OF RECYCLED RUBBER

General Remarks

There are certain technical limitations in the devulcanization of rubbers, and vulcanization is, in fact, not truly reversible. The partial devulcanization of scrap rubber will result in a degradation of physical properties. In many cases, this may limit the amount of substitution levels in high-tech applications such as passenger tires. But it can provide the compounder of less stringent products with an excellent low-cost rubber that can be used as the prime rubber or at very high substitution levels. According to Franta, reclaim cannot be used for tread compounds in tires because every addition may decrease their resistance to wear. However, this statement has not been checked in the case of rubber devulcanized without an addition of chemicals. Considerable amounts of reclaim are consumed for carcasses of bias ply tires for cars if the compounds are of NR, for carcasses of radial tires no reclaim is added. On the other hand, reclaim is added to compounds for bead wires, and it may also be added to sidewalls. Within the framework of direct recycling options, a number of applications for GRT outside the rubber industry have been proposed. Such applications include the use as a filler in asphalt for the surface treatment of roads and as a rubberized surface for sport facilities. The ground scrap rubber can be used as fillers in raw material and plastic compounds. However, the problem of compatibility with the matrix and size of the filler, as well as the discontinuity at the interface between the two phases, should be considered. Rubber products containing ground rubber have low tensile properties due to insufficient bonding between the ground rubber and the virgin matrix. However, this bonding can be improved in the case of the addition of devulcanized rubber.

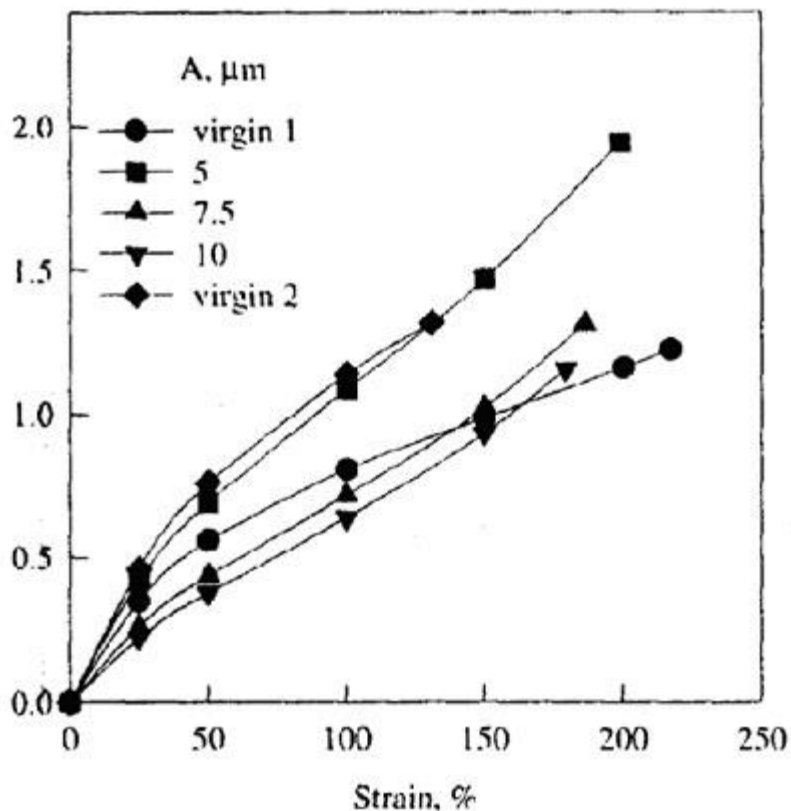

Use in New Tires

The tire is a complicated composite product consisting of tread, under-tread, carcass, inner liner, bead, and sidewall. Many different types of rubber and carbon-black reinforcement are used in manufacturing tires. Therefore, GRT is a blend of various rubbers and carbon blacks. Accordingly, in using GRT powder and devulcanized GRT in new tire manufacturing, many factors should be considered. Evidently, scrap tire powder can be used as a filler for virgin rubbers, and devulcanized GRT can be used in blends with virgin rubbers. This market consumed approximately 50 million lb of scrap tire rubber in 2001.

Until recently, it was generally understood that only a few percent of ground rubber can be used in new tires. The Scrap Tire Management Council reports that 5% of recycled tire rubber is used in an original equipment tire for the Ford Windstar. Although no other information on the amount of devulcanized rubber used in new tires is available in open literature, a possibility exists for the use of up to 10 wt% of recycled tire rubber in new tire compounds. Recently, it was reported that actual road tests of a truck tire containing 10 wt% of the devulcanized rubber in the tread exhibited tread wear behavior almost equal to that for the standard type with the new rubber compound. The increase in the amount of recycled rubber in tires is growing, but it is likely that results will not be available for a number of years.

[^ Top](#)

Post Reviews

Please [Sign In](#) to post reviews and comments about this product.

About NIIR PROJECT CONSULTANCY SERVICES [Hide](#) ▼

NIIR PROJECT CONSULTANCY SERVICES (NPCS) is a reliable name in the industrial world for offering integrated technical consultancy services. Its various services are: Pre-feasibility study, New Project Identification, Project Feasibility and Market Study, Identification of Profitable Industrial Project Opportunities, Preparation of Project Profiles and Pre-Investment and Pre-Feasibility Studies, Market Surveys and Studies, Preparation of Techno-Economic Feasibility Reports, Identification and Selection of Plant and Machinery, Manufacturing Process and or Equipment required, General Guidance, Technical and Commercial Counseling for setting up new industrial projects and industry.

NPCS also publishes various technology books, directory, databases, detailed project reports, market survey reports on various industries and profit making business. Besides being used by manufacturers, industrialists and entrepreneurs, our publications are also used by Indian and overseas professionals including project engineers, information services bureau, consultants and consultancy firms as one of the input in their research.

[^ Top](#)

NIIR PROJECT CONSULTANCY SERVICES (NPCS), 106-E, Kamla Nagar, Delhi-110007, India. • **Email:** npcs.india@Gmail.com • **Website:** NIIR.org • **Tel:** +91-11-23843955, 23845654, 23845886 • **Mobile:** +91-9811043595 • **Fax:** +91-11-23841561
(An ISO 9001:2000 company)