

GLOBAL ORGANIZATION - LOCAL SUPPORT



TIRE CURING MACHINES



VMI GROUP

TKH GROUP MEMBER

YOUR NEEDS - OUR MISSION

In the rubber and tire industry yesterday's technology is being replaced by today's innovation for tomorrow's requirements. Amidst the turmoil of innovation there is, however, one constant:

VMI's commitment to supplying innovative and reliable services and equipment to the rubber and tire industry.

YOUR NEEDS - OUR CHALLENGE

VMI supplies millroom equipment and a complete line of tire manufacturing, curing and testing systems for bias and radial tires for cars, truck, utility and off-the-road vehicles.

Our services range from financing through engineering and contracting projects. We also offer maintenance contracts and upgrade existing rubber and tire equipment.

We work closely with clients to create customised solutions that meet their needs.

Rightfully VMI is known as the leader in millroom equipment and single-stage machines for radial car and truck tires.

YOUR NEEDS - OUR NETWORK

VMI's network of agents is constantly monitoring developments on local markets on all continents. Our R&D department collaborates with the leading international rubber research institutes and with key suppliers of commercial components.

Our vast expertise and experience in rubber and tire production engineering enables us to respond rapidly to market developments and to specific needs of our clients.

For cost-effective systems that are tailored to your requirements, VMI is the company to work with.

YOUR NEEDS - OUR SERVICE

VMI's global organization includes spare-parts supply and servicing from our plants in the Netherlands, USA and P.R. of China. Our service departments are on call 24 hours a day to provide rapid on-site service.

VMI: a partner to rely on in the race against time - and your competitors!

TIRE CURING MACHINES

VMI is proud to introduce the VMI curing press, the column type hydraulic H200T for passenger and light truck tires. With a 52 inch maximum mold diameter and a bead diameter range from 15 to 23 inches, it is capable of curing your tires today and your designs for the future.

The H200T hydraulic curing press was developed by Rogers Industrial Products, Inc. of Akron, Ohio, a company started in 1951. Rogers has supplied new and rebuilt presses of the highest quality to the tire industry since 1973. Rogers' innovative and robust designs set the mark for others to follow.

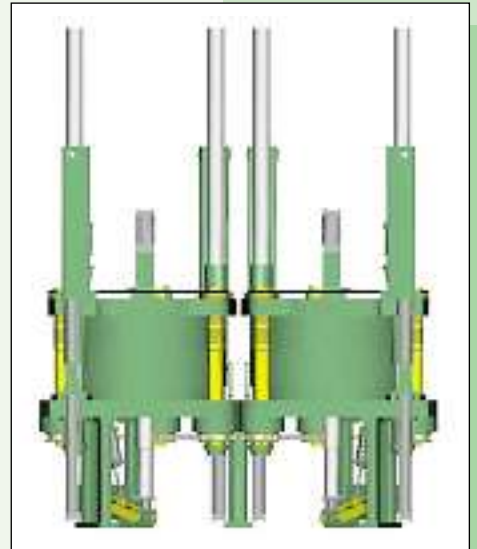

INNOVATIVE FEATURES

The H200T does what no other 52 inch press can do. Specifically:

- It fits into the smallest footprint of any press of its size. Can be used to replace old 40.5 and 42 inch mechanical presses on a one for one basis in the middle of an existing press trench.
- It can be mounted on a level floor, so there is no expensive trench preparation work required.
- Both cavities are completely independent. You can cure what you want in one mold without having to take into consideration what is in the other side. In fact you do not even have to be curing in the other side.
- There are no welds or castings in the squeeze area of the press. Nothing to cause fatigue cracks.
- No lubrication is required. No mess!
- Unsurpassed accessibility. Every part of the press is designed for ease of maintenance.
- Low pressure hydraulics ensure that it will not leak.
- Fastest cycle time in the industry.

All things considered, it is the piece of equipment that will cure your tires at the lowest cost per tire.



COMPACT SIZE

Do you need a 52 inch curing press that can be installed on 14 foot centers? Well this one can be and still leave sufficient room for access. You can add capacity to cure the big tires without having to reduce the number of curing presses in your facility. Think what that can mean to your profitability.

UNIQUE CONSTRUCTION

This press is designed to "infinite life" standards. This was accomplished using state-of-the-art computer aided design and finite element analysis. Even at maximum squeeze, the total deflection of the top and bottom bolsters is less than the thickness of a sheet of paper. No welds and no castings avoid problems in later life. It is the press that can be shipped to your facility in a standard 20ft container for low shipping cost and shipment integrity.

TIRE QUALITY

Because of the near zero deflection and the superior guide rod design, the VMI press is the solution that will give you optimum tire uniformity. We allow you to give your customers the best tire you can build. The VMI press is the logical enhancement to VMI component preparation equipment and tire building machines.

FLEXIBILITY

It does not get any better than this. The H200T makes changing codes fast and precise. It includes automatic mold height adjustment as the computer takes care of it all. The segmented mold actuator comes with an automatic bayonet lock. And remember that this press can operate each side completely independently.

LEAK-PROOF DESIGN

Leak-free press components result from using low pressure hydraulics. This means low maintenance and more production. The use of hydraulic cylinders has been minimized and many techniques for oil leak prevention have been applied, from proper cylinder application to special oil line fittings.

CENTER POSTS

The press is available in either the "standing post" or "post in well" configuration. In either case, the center post is supplied using the proprietary Rogers design which provides optimally even-heat distribution inside the bladder. Bladder stretch is PLC controlled for quick setup and reduced maintenance.

DESIGNED TO FIT YOUR OPERATION

The options for loading, unloading, post cure inflation meet every known requirement in the tire industry. The H200T is the press that will meet all of your requirements in tire curing and exceeds your expectations.

Don't settle for less than what you want and need!

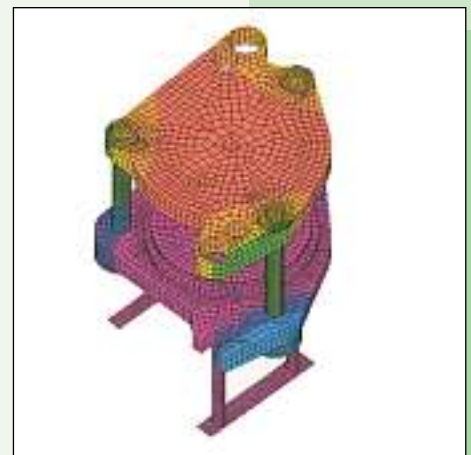
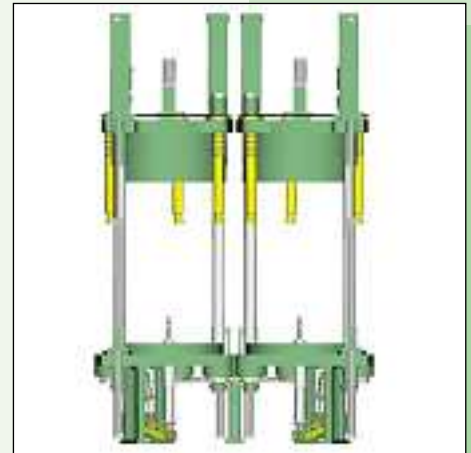

TECHNICAL SPECIFICATIONS H200T

Tire bead range	15" – 23"
Closing Force	1,855 kN
Max mold diameter (inside shields)	1321 mm
Mold height range	355 – 559 mm
Max green tire height	660 mm
Max green tire diameter	990 mm
Max cured tire height	508 mm
Max cured tire diameter	1016 mm
Steamplate thickness	76 mm
Heater plate diameter	1300 mm
Max bladder pressure	27 bar
Max oil hydraulic requirement	117 bar / 11.7 Mpascal
Total Weight	20,000 kg
Machine width	3600 mm

VMI PRESSES FOR TRUCK TIRES

The unique design of the H200T press can be applied to larger presses for curing Truck - Bus radial tires. The 65 inch H1000T is designed for low unit cost curing in the rigorous environment associated with heavy tire curing.



**VMI SUPPLIES A COMPREHENSIVE
RANGE OF MACHINERY FOR RUBBER
COMPOUND HANDLING, MANUFACTURING
OF TIRE COMPONENTS, TIRE ASSEMBLY,
TIRE CURING AND TIRE TESTING FOR THE
PRODUCTION OF RADIAL PASSENGER,
LIGHT TRUCK, ALL STEEL RADIAL TRUCK
AND BUS AND OFF THE ROAD TIRE.**

For more information see:

www.vmi-group.com

or contact us by e-mail:

sales@vmi-group.com

HEADQUARTERS:

P.O.Box 161, 8160 AD Epe
The Netherlands
sales@vmi-group.com
phone +31 578 679111

**SALES OFFICES:
STOW, OHIO, USA**

sales@vmi-usa.com
phone +1 330 9296800

YANTAI, SHANDONG, CHINA

vmiy@vmi.com.cn
phone +86 535 6300139

KUALA LUMPUR, MALAYSIA

dennis@isoelectra.com.my
phone +60 3 78469988

MOSCOW, RUSSIA

office@vmi-group.ru
phone +7 495 7950332

RUNDING, GERMANY

info@vmi-az.com
phone +49 9971 76139-0

BERGAMO, ITALY

sales@vmi-group.com
phone +39 0307 365399

SAO PAULO, BRAZIL

raraujo@vmi-az.com
phone +55 11 22792520

WORLD WIDE SUPPORT

24 HOURS AT CALL: + 31 651 533 912

